



Smart Network Video Recorder

User Manual





Foreword

General

This manual introduces the installation, functions and operations of the N1L series smart network video recorders (hereinafter referred to as NVR). Read carefully before using the device, and keep the manual safe for future reference.

Safety Instructions

The following signal words might appear in the manual.

Signal Words	Meaning
 DANGER	Indicates a high potential hazard which, if not avoided, will result in death or serious injury.
 WARNING	Indicates a medium or low potential hazard which, if not avoided, could result in slight or moderate injury.
 CAUTION	Indicates a potential risk which, if not avoided, could result in property damage, data loss, reductions in performance, or unpredictable results.
 TIPS	Provides methods to help you solve a problem or save time.
 NOTE	Provides additional information as a supplement to the text.

Revision History

Version	Revision Content	Release Time
V1.0.0	First release	September 2025

Privacy Protection Notice

As the device user or data controller, you might collect the personal data of others such as their face, audio, fingerprints, and license plate number. You need to be in compliance with your local privacy protection laws and regulations to protect the legitimate rights and interests of other people by implementing measures which include but are not limited: Providing clear and visible identification to inform people of the existence of the surveillance area and provide required contact information.

About the Manual

- The manual is for reference only. Slight differences might be found between the manual and the product.

- We are not liable for losses incurred due to operating the product in ways that are not in compliance with the manual.
- The manual will be updated according to the latest laws and regulations of related jurisdictions. For detailed information, see the paper user's manual, use our CD-ROM, scan the QR code or visit our official website. The manual is for reference only. Slight differences might be found between the electronic version and the paper version.
- All designs and software are subject to change without prior written notice. Product updates might result in some differences appearing between the actual product and the manual. Please contact customer service for the latest program and supplementary documentation.
- There might be errors in the print or deviations in the description of the functions, operations and technical data. If there is any doubt or dispute, we reserve the right of final explanation.
- Upgrade the reader software or try other mainstream reader software if the manual (in PDF format) cannot be opened.
- All trademarks, registered trademarks and company names in the manual are properties of their respective owners.
- Please visit our website, contact the supplier or customer service if any problems occur while using the device.
- If there is any uncertainty or controversy, we reserve the right of final explanation.

Important Safeguards and Warnings

This section introduces content covering the proper handling of the device, hazard prevention, and prevention of property damage. Read carefully before using the device, and comply with the guidelines when using it.

Operation Requirements

- The device should not be wall-mounted with the front panel facing down. Please install it horizontally or in a stable location to prevent it from falling.
- Do not install the device in areas that are damp, dusty, or smoky.
- Keep liquids away from the device to avoid spills or splashes. Do not place any items filled with liquid on or around the device.
- Ensure adequate airflow around the device by installing it in a well-ventilated area and keeping the air vents unblocked.
- Do not disassemble the device without proper authorization or guidance.
- Always transport, use, and store the device within the allowed humidity and temperature limits.
- For device safety, connect it to the power adapter prior to plugging adapter into the electrical outlet. Once all connections are secured, turn on the power switch, if available.
- Refrain from placing or installing the device in direct sunlight or near heat sources.
- The device is designed to operate within the specified input/output range, requiring a power supply of 12 VDC 2 A. Please use the supplied power adapter if included.
- Operating temperature: -10°C to + 45°C (+14°F to +113°F).

Power Requirements

- The product shall use electric wires (power wires) recommended by this area, which shall be used within its rated specification.
- Make sure to use standard power adapter matched with this device. Otherwise, the user shall undertake resulting personnel injuries or device damages.
- Use power supply that meets SELV (safety extra low voltage) requirements, and supply power with rated voltage that conforms to Limited Power Source in IEC60950-1. For specific power supply requirements, please refer to device labels.
- Products with category I structure shall be connected to grid power output socket, which is equipped with protective grounding.
- Appliance coupler is a disconnecting device. During normal use, please keep an angle that facilitates operation.

Table of Contents

Foreword	II
Important Safeguards and Warnings	IV
1 Product Information	1
1.1 Overview	1
1.2 Features	1
2 Panel Layout	2
2.1 Front Panel.....	2
2.2 Rear Panel	3
3 Device Installation	4
3.1 Startup Diagram.....	4
3.2 Unboxing Inspection	4
3.3 Hard Drive Installation	4
3.4 Connection.....	6
4 Get Started	8
4.1 Power On and Off.....	8
4.2 NVR Initialization	8
4.3 Startup Wizard.....	12
4.3.1 IP Setting.....	13
4.3.2 Cloud Services.....	14
4.3.3 HDD Manager.....	15
4.4 General Mouse Operations.....	15
4.5 Log In	16
4.6 Admin Password Recovery	17
5 Use the System	20
5.1 Interface Overview	20
5.2 Camera Settings	21
5.2.1 Add Devices	21
5.2.2 Image Properties.....	32
5.2.3 Overlay.....	33
5.2.4 Encode.....	34
5.2.5 Detection	36
5.2.6 Alarm	40
5.2.7 PTZ.....	41
5.3 Live View.....	44
5.3.1 Interface Overview	44
5.3.2 Camera Connection Shortcut.....	45
5.3.3 Mouse Operations for Live View.....	46
5.3.4 Channel Toolbar	46
5.3.5 Control Menu	48
5.3.6 PTZ.....	49
5.4 Playback.....	50
5.4.1 Interface Overview	50

5.4.2 Mouse Operations for Playback.....	53
5.4.3 Playback Toolbar	53
5.4.4 Video Mark.....	54
5.4.5 Smart Search.....	58
5.4.6 Video Clip.....	60
5.4.7 File List.....	60
5.5 Backup.....	65
5.5.1 File Backup	66
5.5.2 Log Backup.....	67
5.5.3 Config Backup.....	67
5.6 Display Settings.....	68
5.6.1 Display.....	68
5.6.2 Tour.....	69
5.7 Network Settings.....	71
5.7.1 Network Configuration.....	71
5.7.2 Port.....	72
5.7.3 Cloud Services.....	73
5.7.4 Network.....	74
5.8 Storage.....	76
5.8.1 Schedule.....	76
5.8.2 HDD Manager.....	78
5.8.3 Backup	79
5.9 Alarm	79
5.9.1 Alarm Info	79
5.9.2 Abnormality.....	80
5.9.3 Alarm Linkage	81
5.10 System Settings.....	82
5.10.1 Basic Configuration.....	82
5.10.2 Date	83
5.10.3 Account.....	84
5.10.4 Maintenance	88
5.10.5 Version Information.....	91
5.10.6 Log	91
6 FAQ	94
Appendix 1 Cybersecurity Recommendations.....	96

1 Product Information

1.1 Overview

An NVR (Network Video Recorder) is a critical component in modern video security systems, designed to store, manage, and process digital video footage from security cameras. Featuring multi-channel access, it delivers stable connectivity with expansive coverage. With auto-connection for newly added cameras, setup is effortless, while HDMI/VGA outputs ensure compatibility with most displays. Either configure or control the NVR system on the local monitor or remotely access from the Imou Life app, it is an ideal protector for your home and business.

1.2 Features

- Total connectivity: 10 channels or 18 channels (based on NVR model)
- Built-in mic + speaker: Instant two-way audio
- Auto connection: Supports seamless addition of newly added cameras
- IMOU app integration: Full camera configuration and control via mobile app
- Video outputs: HDMI (up to 4K) and VGA (up to 1080p) support for flexible monitoring
- Storage: Single-bay design, supports up to 16TB 3.5" HDD

2 Panel Layout

2.1 Front Panel



The following figures of the front and rear panels are for reference only. The actual product may differ.

Figure 2-1 Front Panel

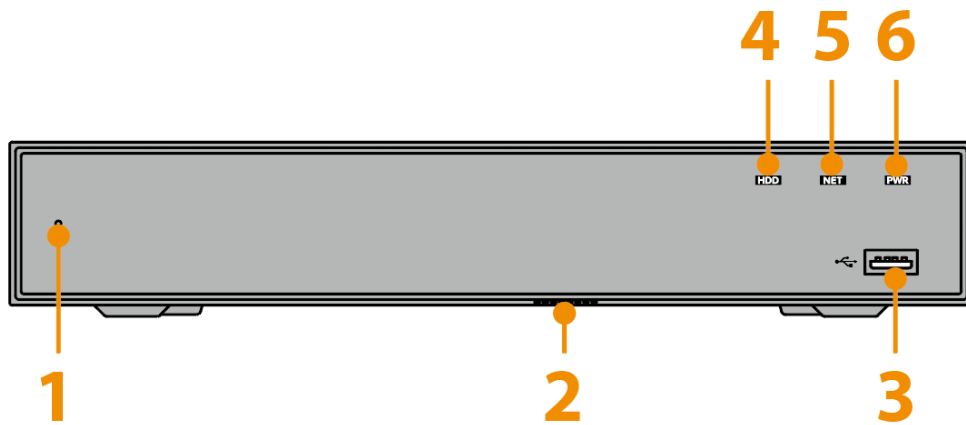
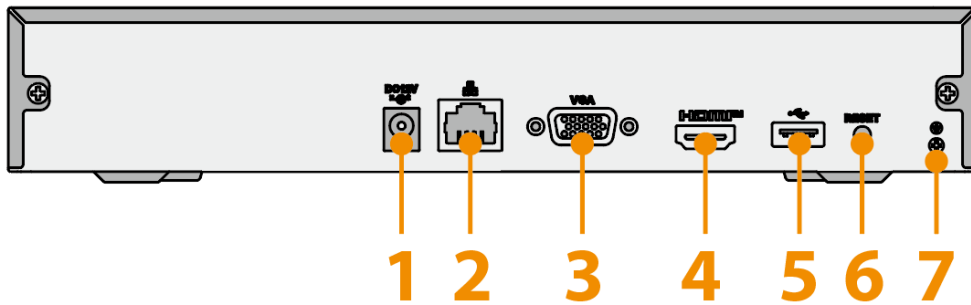

Table 2-1 Front Panel Components

No.	Item	Description
1	Microphone	Captures sound from the user's environment or voice.
2	Speaker	Delivers sound to the user.
3	USB Port	Connect to peripheral USB storage device, mouse, etc.
4	HDD Status Indicator	<ul style="list-style-type: none"> ● Off: Hard drive functions properly ● Solid red: Hard drive error/No hard drive
5	Network Status Indicator	<ul style="list-style-type: none"> ● Off: Wired network connection is normal ● Solid red: Wired network connection error
6	Power Status Indicator	<ul style="list-style-type: none"> ● Off: Power connection error ● Solid green: Power is connected

2.2 Rear Panel

Figure 2-2 Rear Panel



Rear Panel Components

No.	Item	Description
1	Power Port	Inputs 12 VDC 2 A power.
2	Ethernet Port	Self-adaptive network port that connects an Ethernet cable.
3	VGA Port	Outputs up to 1080p analog video signals to the connected monitor.
4	HDMI Port	Transmits up to 4K high-definition video and multi-channel audio to the HDMI port of the display device.
5	USB Port	Connects to peripheral USB 2.0 storage device, mouse, etc.
6	Reset Button	For factory reset, hold down the reset button for 5 seconds.
7	Grounding Terminal	Keeps your NVR safe by dumping harmful electricity into the ground.

3 Device Installation

3.1 Startup Diagram

Follow the processes below to install and prepare your device.



Step 1 Verify the equipment's exterior condition, packaging, and labels for any damage.

Step 2 (Skip if the HDD has been installed) Install the hard disk drive (HDD) following "3.3 Hard Drive Installation."

Step 3 Connect cables for both the NVR and cameras. See "3.4 Connection."

Step 4 Power on all devices.

Step 5 Start the initial configurations. Refer to "4 Get Started."

3.2 Unboxing Inspection

Upon receiving the device, examine the outer packaging for any signs of damage or clash. Ensure all items are included and inspect the whole device to see if there are any physical defects. Check that the labels on the device are intact and undamaged. Keep the label well, which may be required for after-sales service.

3.3 Hard Drive Installation



Skip this section if your NVR comes with a pre-installed hard drive.

To store video recordings and other data, you must install a compatible hard drive. For optimal performance and reliability, use enterprise-grade HDDs.

- Please prepare a 3.5-inch mechanical hard disk drive. Up to 16TB capacity is supported. Before installation, disconnect the NVR from the power.
- Use the professional SATA HDD for monitoring.
- Unplug the power if you want to replace the HDD.

Step 1 Remove four screws on the side and rear of the upper cover.

Figure 3-1 Remove Screws

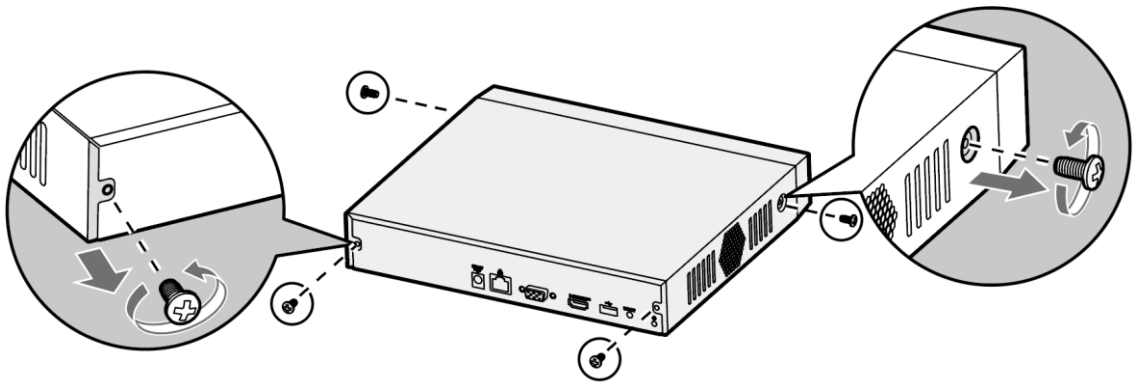

Step 2 Carefully lift the cover away.

Figure 3-2 Remove Cover

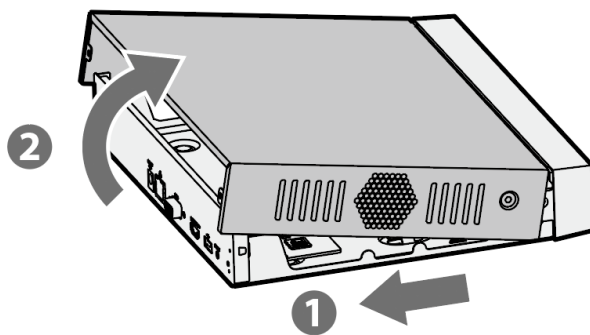

Step 3 Plug in the data and power cables into their respective connectors on the hard drive and NVR.

Figure 3-3 Connect Cables

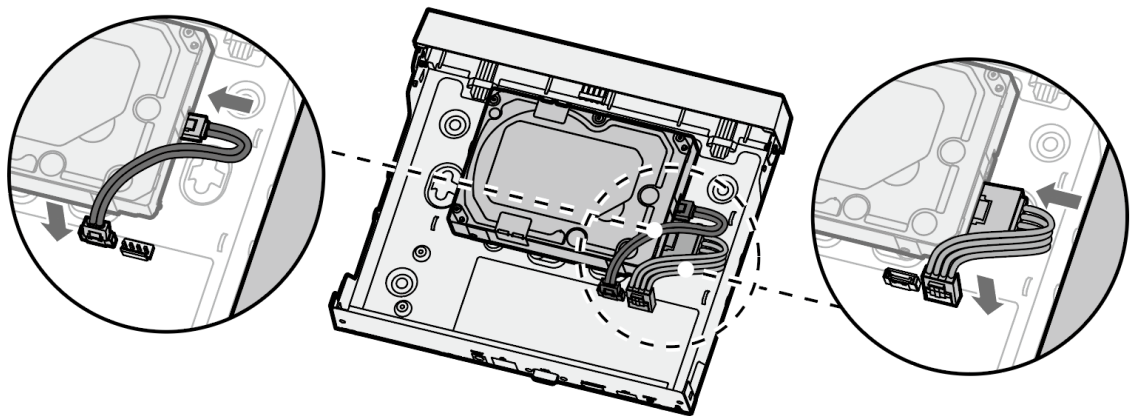

Step 4 Flip over the NVR. Align the hard drive with the four screw holes at the bottom of the NVR and secure it with provided screws.

Figure 3-4 Fix HDD

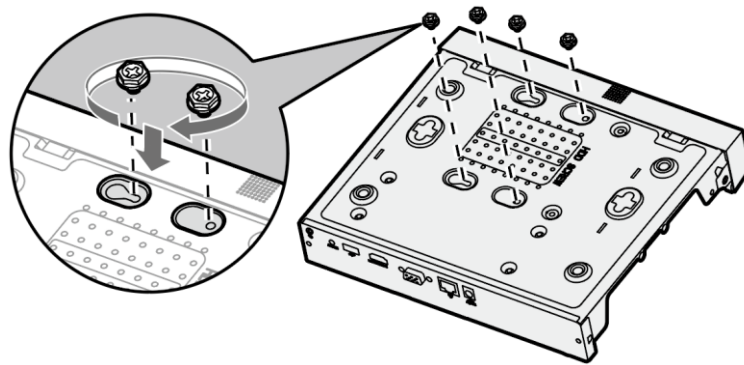

Step 5 Replace the cover.

Figure 3-5 Replace the Cover

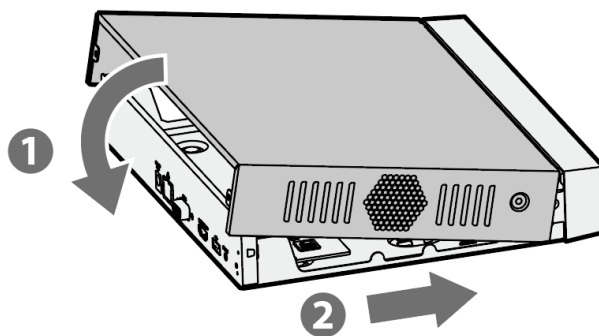

Step 6 Fasten the cover using previously removed screws.

Figure 3-6 Replace Screws

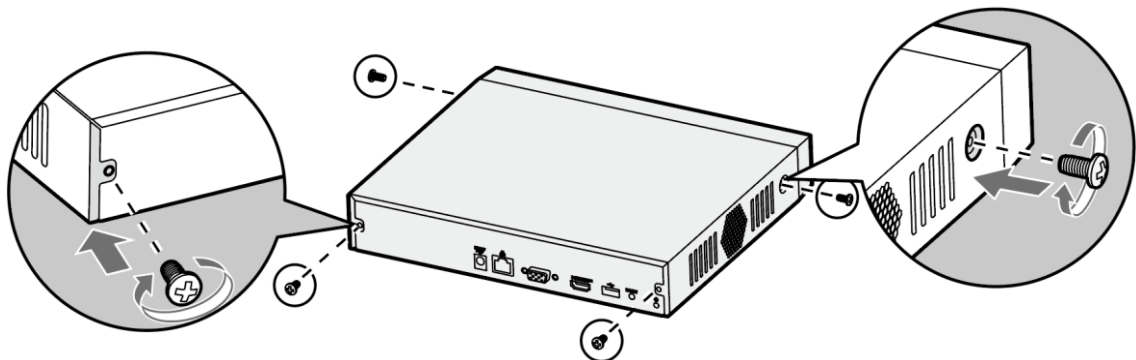

3.4 Connection

Instructions below are for cameras connected to the NVR via wire.



- If you have multiple wired cameras, it is recommended to connect them to a switch and connect the switch to a router.
- For wired camera installation, select a spot with clear visibility and easy cabling. Keep the Ethernet cable under 100 meters. If power access is limited, use a PoE camera powered via a PoE switch.

Figure 3-7 Wired Connection

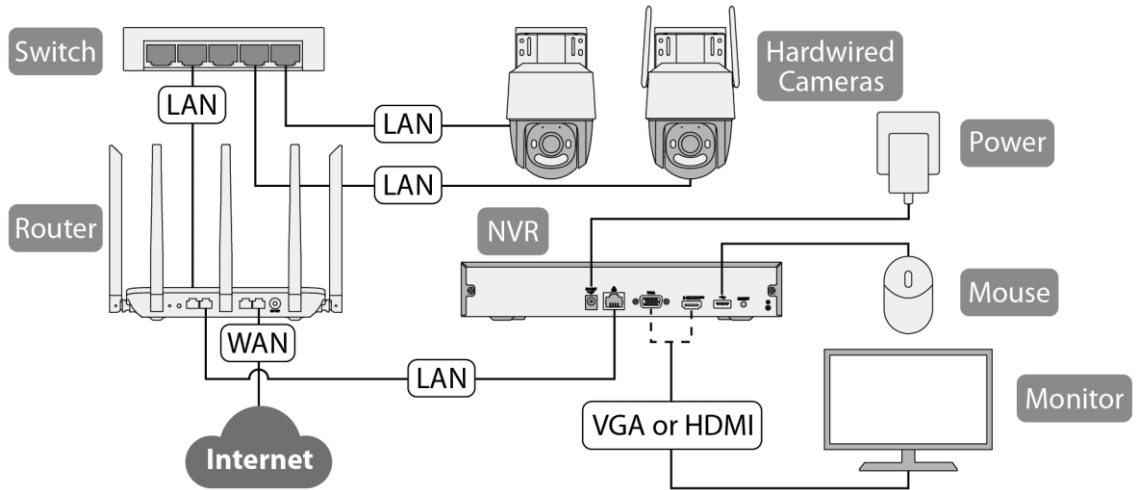

4 Get Started

Includes basic operations such as turning NVR on/off, device initialization, and startup wizard.

4.1 Power On and Off



- For device safety, connect it to the power adapter prior to plugging adapter into the electrical outlet. Once all connections are secured, turn on the power switch, if available.
- The device is designed to operate within the specified input/output range, requiring a power supply of 12 VDC 2 A. Please use the supplied power adapter if included.
- Use a stable and low-noise power supply to ensure NVR reliability and HDD durability.

Power on

Step 1 Connect a monitor to the NVR.

Step 2 Plug the NVR in using the provided power adapter to turn it on.

Shut down

Step 1 Right-click on the live interface, then select **Main Menu**.

Step 2 Click  in the upper-right corner, and select **Shutdown**.

Step 3 Unplug the power once the screen goes black and a shutdown confirmation is displayed. Do not disconnect the device from power while data is being saved or video recording is in progress.

4.2 NVR Initialization

For first use, the device will undergo initialization, which include creating a password for the default admin account, filling in the answers used for password reset, etc.



For your device safety, keep the **admin** password well and change it regularly.

Step 1 Boot up the NVR and wait for it to finish loading. On the **Device Initialization** interface, select your region, language and video standard then click **Next** to continue.

Figure 4-1 Device Initialization (1)

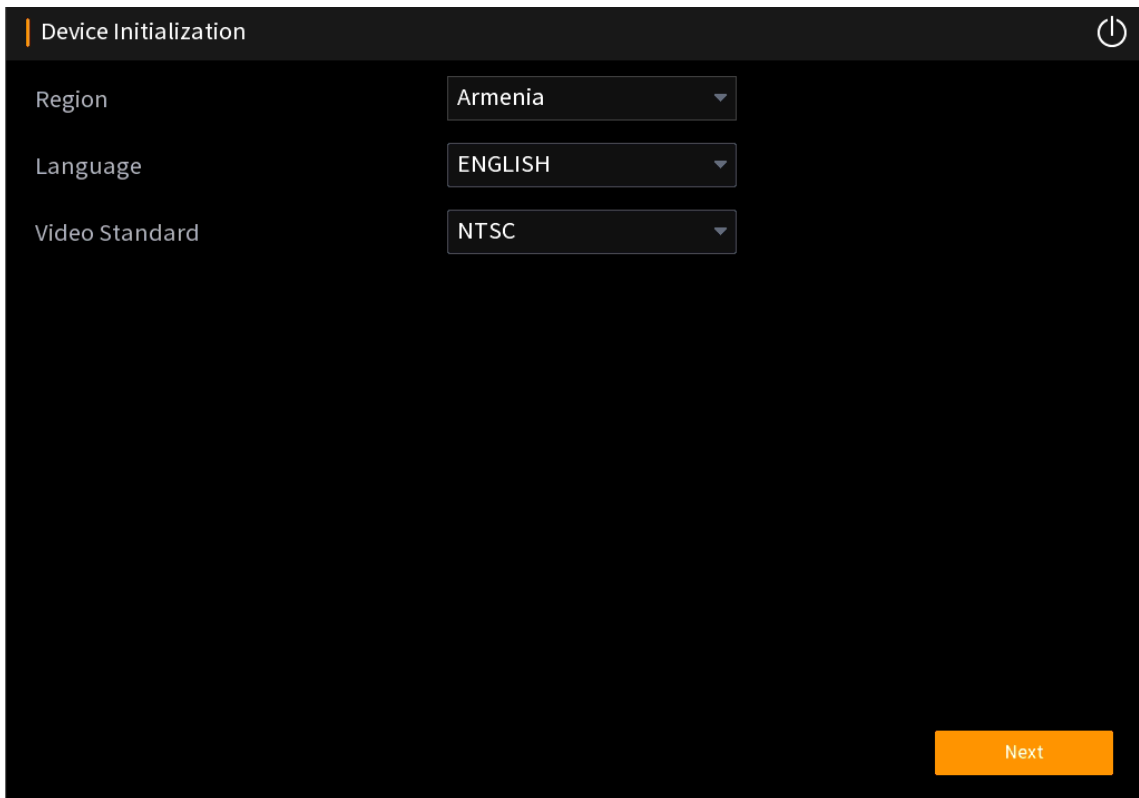

Step 2 Read and agree to the license agreement, then set your time zone as well as current date and time.

Figure 4-2 Device Initialization (2)

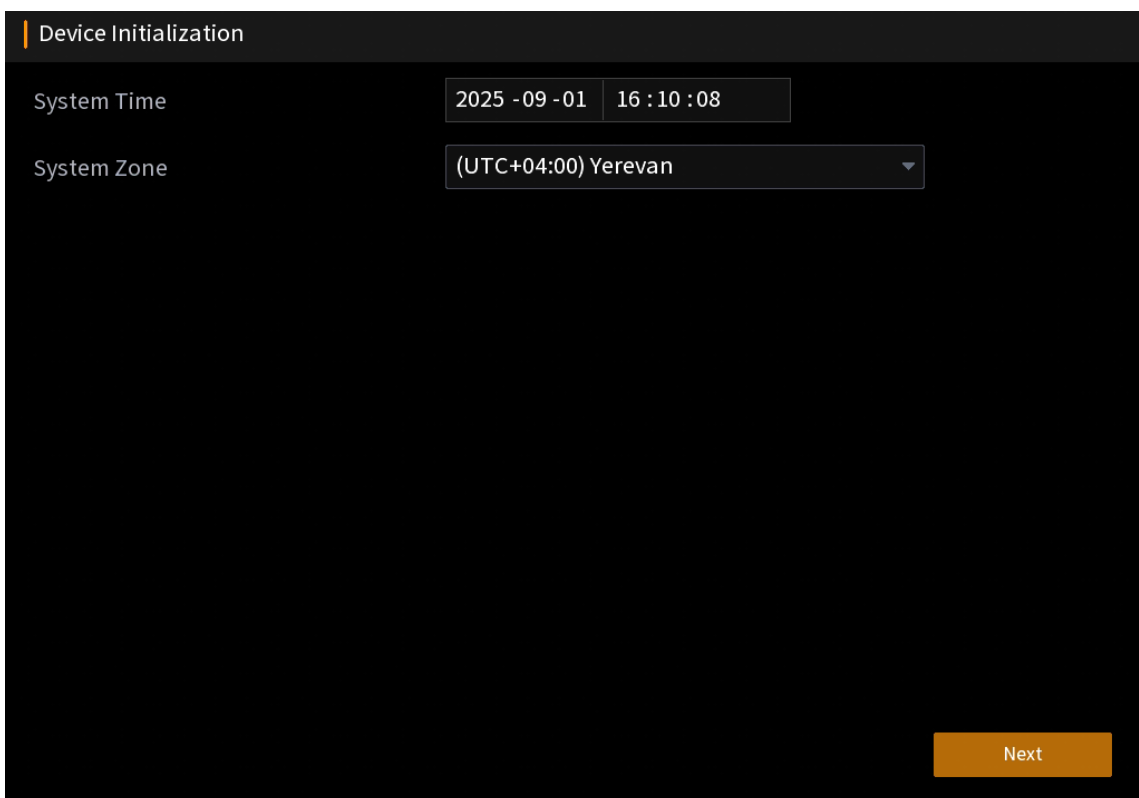

Step 3 For the authentication of the default user admin, either:

- Method 1: Use the Safety Code printed on the NVR label as the password.

Figure 4-3 Use Safety Code

Device Initialization

1 Enter Password → 2 Unlock Pattern → 3 Password Protection

Use safety code of the NVR

Username admin

Password [Masked]

Prompt Question This is your NVR's safety code, which is labeled on the device.

Next

- Method 2: Uncheck the box and create a custom password, then click **Next**.

Figure 4-4 Create Admin Password

Device Initialization

1 Enter Password → 2 Unlock Pattern → 3 Password Protection

Use safety code of the NVR

Username admin



Password [Empty] Password length is between 8 an...

Confirm Password [Empty]

Prompt Question [Empty]

Next

Table 4-1 Create Admin Password

Item	Description
Username	By default, the user is admin .
Password	Create admin's password.
Confirm Password	The password should be 8-32 characters long and contain at least two types from numbers, letters or symbols (except ' " ; : &). Follow the strength meter to create a high-security password.
Prompt Question	Enter the information that can remind you of the admin's password.  On the Login interface, hover on the  to see password hints. The function is exclusive to the admin account.

Step 4 (Optional) Draw an unlock pattern and confirm it.



- Click **Skip** if you do not want to configure the unlock pattern, which can be manually turned on in **Main Menu > System > User Account** if needed. Refer to "5.10.3.1 User Account" for details.
- Once configured, the unlock pattern will replace the password as the default login method.

Figure 4-5 Unlock Pattern

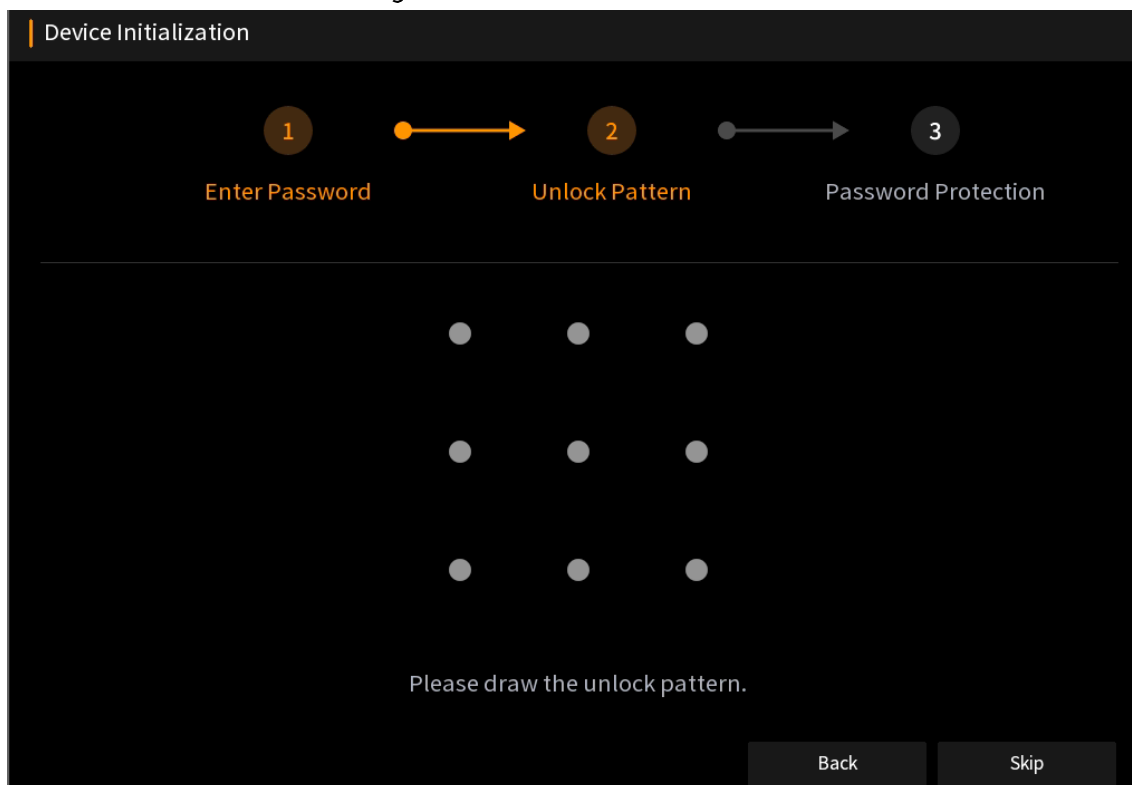

Step 5 Select the security questions and fill in the answers, then click **OK**. The initialization is complete.



Correct answers to these questions will allow you to reset the admin password if forgotten. To modify the security questions, right-click on the live view and navigate to **Main Menu > System > Account > Password Reset**. See "5.10.3.2 Reset Security Questions" for details.

Figure 4-6 Password Protection

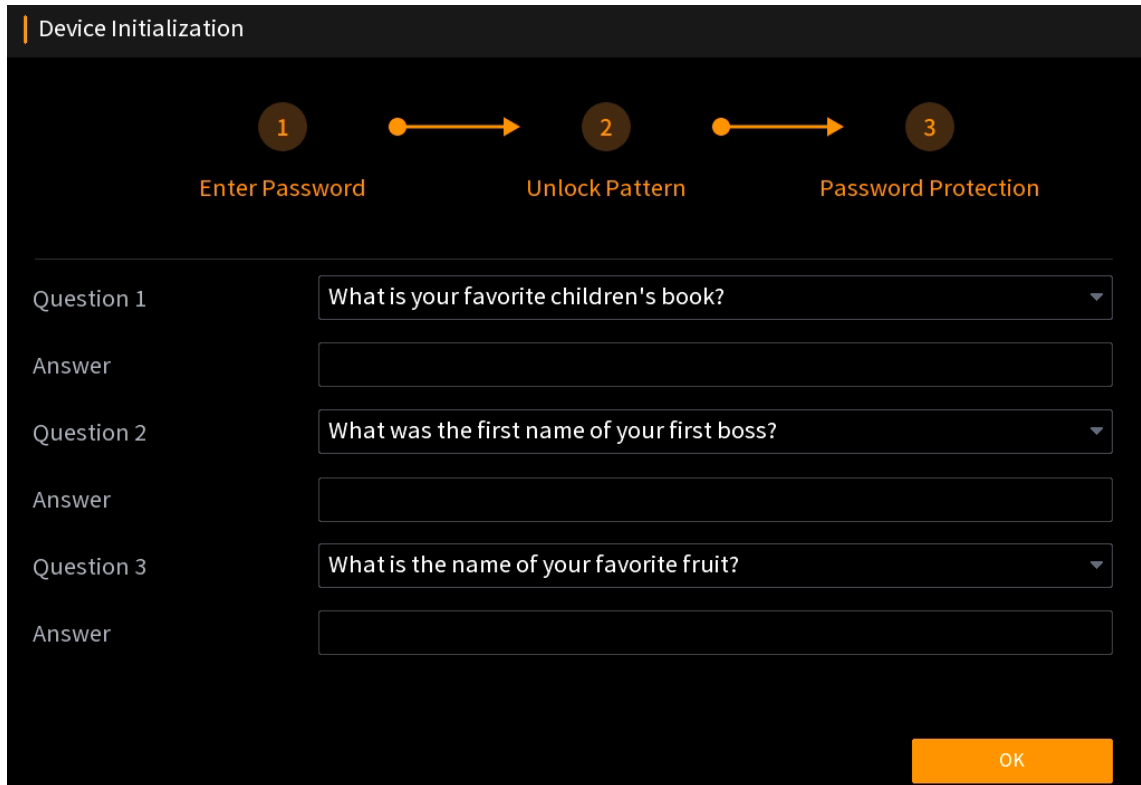

4.3 Startup Wizard

For the first use, after initialization, the startup wizard will guide you through quick settings of the NVR, such as IP parameters, update issues and HDD management.



Auto check for updates will permit the system to check for updates daily. To check for the new version, go to **Main Menu > System > Maintenance > NVR Firmware Upgrade**. Be aware of the information collection if you turn the feature on.

Figure 4-7 Startup Wizard

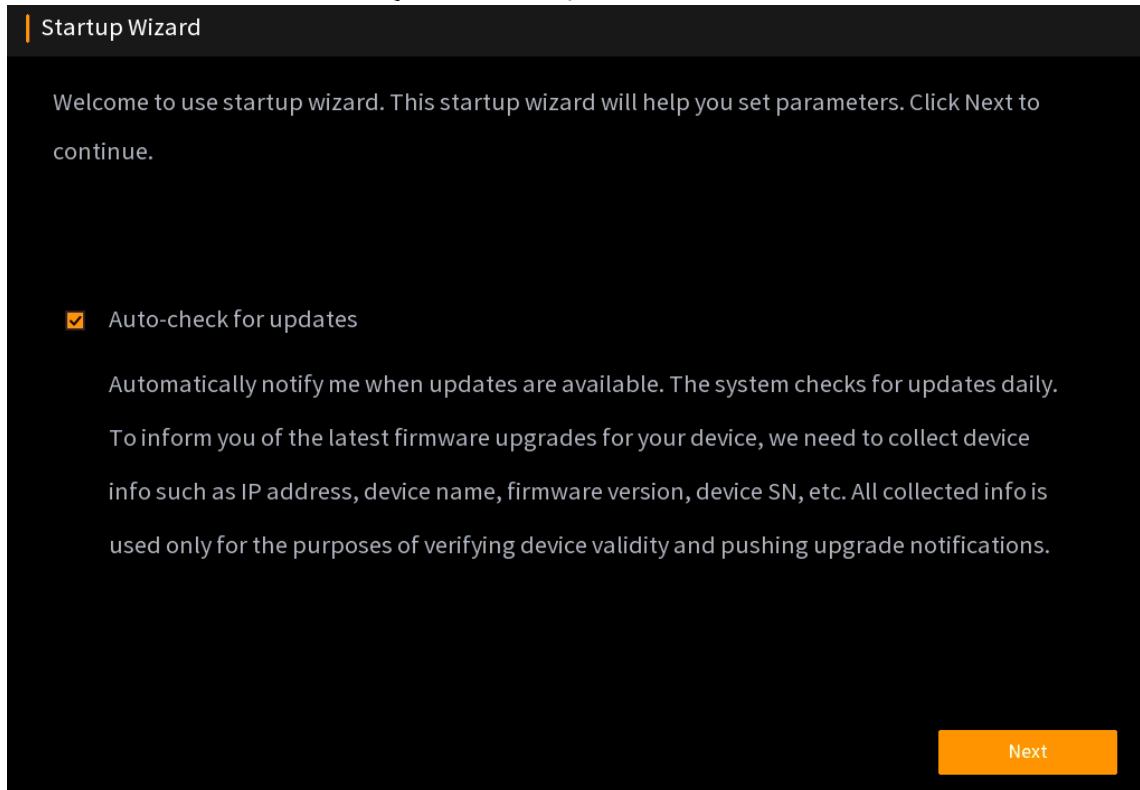

4.3.1 IP Setting

Make network configurations of the NVR such as IP, MAC, DNS settings, etc.



- Make sure the NVR has connected to the network properly.
- The following network configurations can also be made at **Main Menu > Network > Network Config.**

Figure 4-8 IP Setting

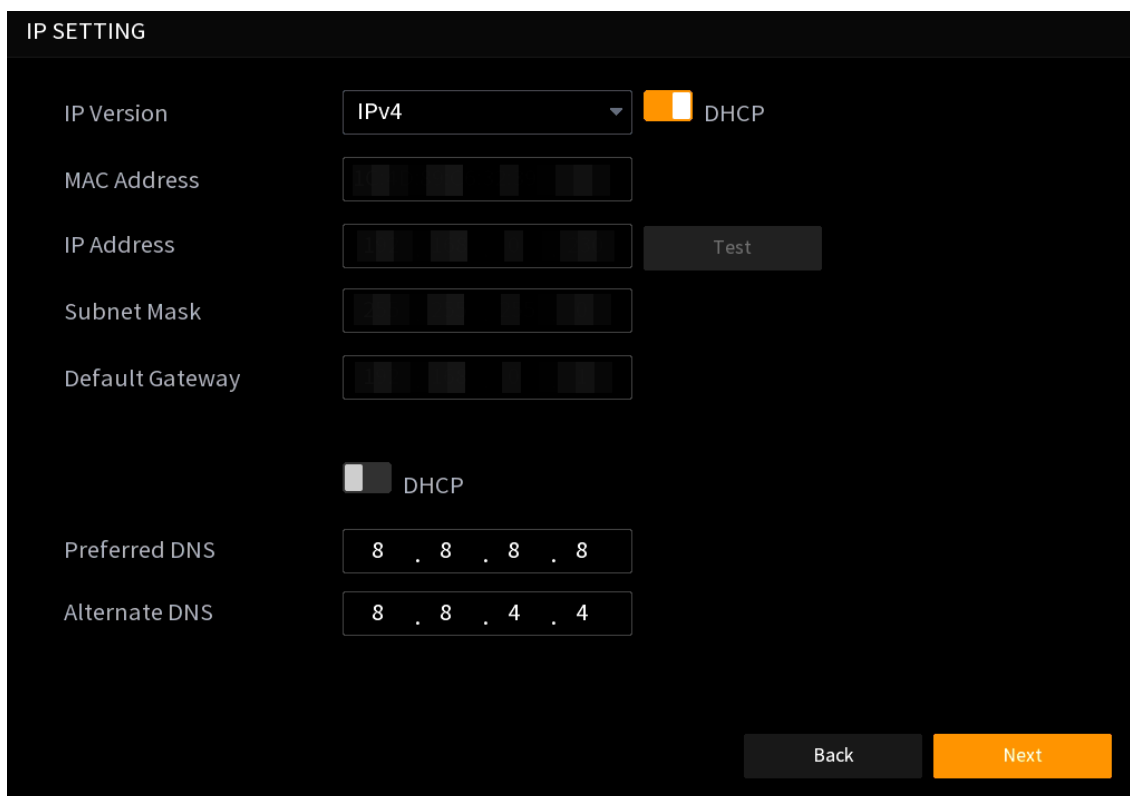



Table 4-2 IP Setting

Item	Description
IP Version	Both IPv4 and IPv6 addresses are supported and switchable.
MAC Address	Displays the MAC address of the NVR.
DHCP	When DHCP is enabled and works correctly, it automatically assigns the IP address, subnet mask, and default gateway, making these fields non-configurable. To manually configure these parameters, disable DHCP first. Afterwards, click Test to check for IP addresses conflicts.
IP Address	
Subnet Mask	
Default Gateway	
	 IP address and default gateway must be in the same network segment.
DNS DHCP	When the above DHCP is enabled and functioning, turn on the DHCP for DNS will automatically assign the DNS IP addresses. To manually enter these IPs, disable the DHCP for DNS.
Preferred DNS	The IP address of the primary DNS server.
Alternate DNS	The IP address of the backup DNS server.

4.3.2 Cloud Services

After enabling the **Cloud Services** and adding the NVR to the Imou Life app, you can access the NVR and its connected cameras remotely through the Imou Life app. Refer to "5.7.3 Cloud Services" for guides.

4.3.3 HDD Manager

If a hard drive is installed, you can view its information here, including its identification, read/write type, health status and storage usage (free/used space).



- To erase all the data in the HDD, tick the HDD and click **format**.
- Alternatively, access the HDD manager via **Main Menu > Network > HDD Manager**. See "5.8.2 HDD Manager."

Figure 4-9 HDD Manager

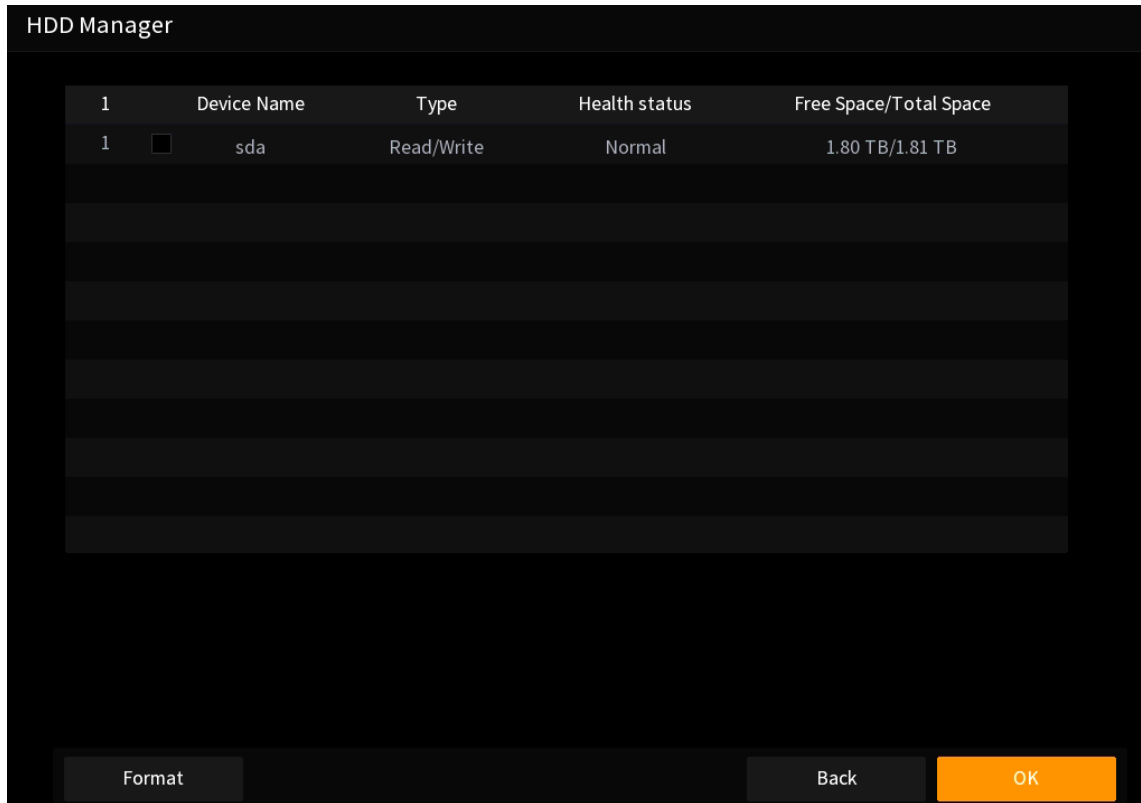

4.4 General Mouse Operations







The following instructions assume a right-handed mouse setup.

Insert the USB mouse into the USB port on the device panel.

Table 4-3 Mouse Operations

Operation	Description
Left-Click	Left-click an item to enter or select.
	Execute the operation.
	Left-click the combo box to expand its dropdown list.

Operation	Description
	<p>Left-click the corresponding button on the panel to input numbers, English letters (both lowercase and uppercase), or symbols.</p>  <p>: Backspace –Deletes the character to the left of the cursor.</p> <p>: Space</p> <ul style="list-style-type: none"> • Insert a blank space between characters. • For pure digit entry, click  to clear all entered digits at once in this field.
Double-Click (Left)	<p>Perform special operations, such as double-clicking a recording file in the list to play it back.</p> <p>In multi-screen view (1/8 view excepted): Double-click any channel to maximize it; Double-click again to restore the multi-screen layout</p>
Right-Click	<p>On live interface, right-click to access the main menu (login required if inactive).</p> <p>In settings or playback menu, right-click to exit the current menu.</p>
Scroll Wheel	<p>Adjust numerical values in input fields by scrolling up/down.</p> <p>Switch between options in a combo box.</p> <p>Scroll up/down the list.</p>
Mouse Movement	<p>Hover to select a control or an item under the cursor.</p>
Mouse Drag	<p>Drag to select or draw a specific area.</p>

4.5 Log In

For security, the system will log out after a period of inactivity and return to the live view interface. Please log in again before further operations.

Step 1 To log in, right-click on the live view and click any option to pop up the login interface.

Step 2 Verify your identity.

- If an unlock pattern is enabled, draw it to authenticate. Alternatively, click **Forgot Pattern** or **Select User** to switch to the password entry.

Figure 4-10 Verify Unlock Pattern

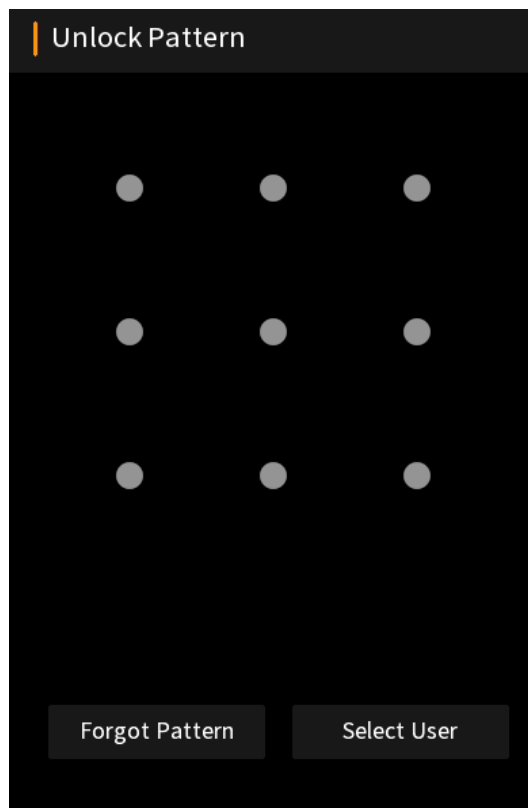

- If no pattern is set, simply enter the password to log in.

Figure 4-11 Enter the Password

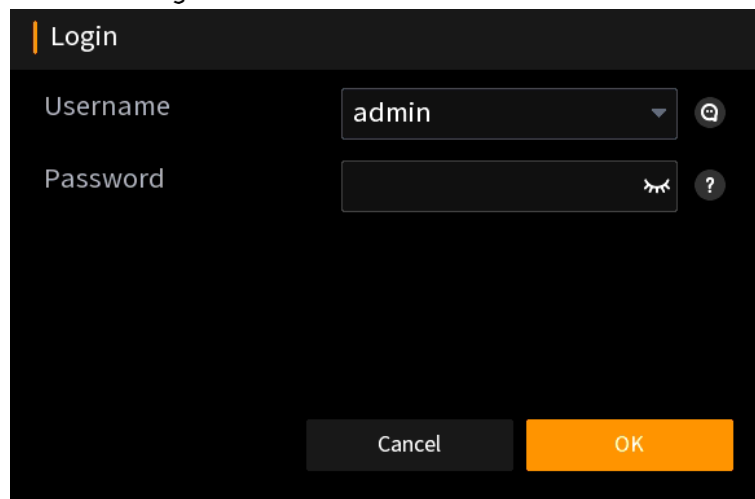

4.6 Admin Password Recovery

In case you forget the password of admin, you can retrieve it with security questions.



Only the default admin account allows password reset via security questions. For other users, refer to "5.10.3.1 User Account" to change passwords or restore the device to factory settings.

Step 1 (Skip if you do not set an unlock pattern) Click **Forgot Pattern**.

Figure 4-12 Forgot Pattern

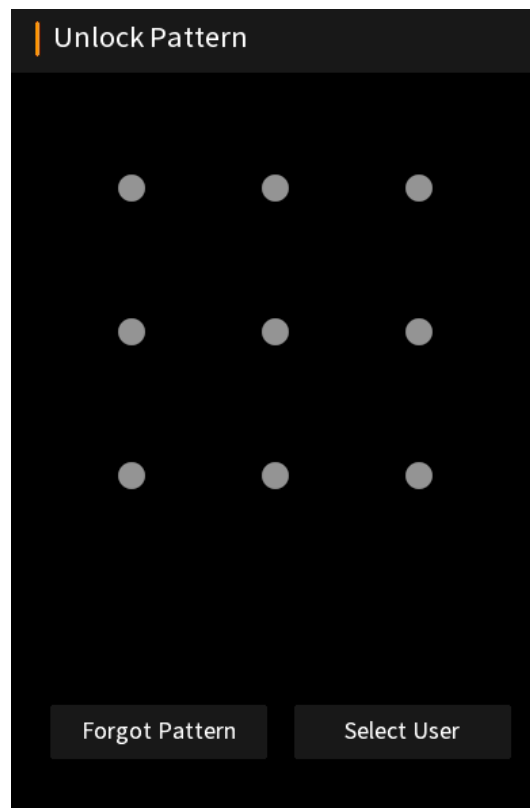

Step 2 Click  on the **Login** interface.

Figure 4-13 Password Recovery



Step 3 Enter the answers to the security questions and click **Next**.

Figure 4-14 Answer Security Questions

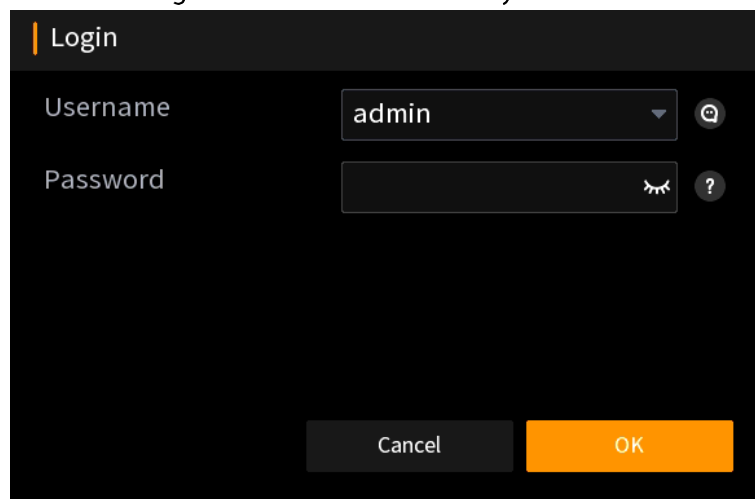
Reset Password

Question 1: What is your favorite children's book?

Answer:

Question 2: What was the first name of your first boss?

Answer:

Question 3: What is the name of your favorite fruit?

Answer:

Cancel Next

Step 4 Create a new admin password, confirm it and click **OK**.



The password should be 8-32 characters long and contain at least two types from numbers, letters or symbols (except ' " ; : &). Follow the strength meter to create a high-security password.

Figure 4-15 Reset Password

Reset Password

Username: admin

New Password: Password length is between 8 and 32 characters, and it includes at least two types from numbers, letters and general characters (Any characters except ' " ; : &)

Confirm Password:

Cancel OK

5 Use the System

This section is the central hub for operating your NVR, including live view, video playback, camera connection and settings for configuring cameras, display, alarms, network, storage and system maintenance.



Minor variations may exist and your device's actual interface shall prevail.

5.1 Interface Overview

Figure 5-1 Interface Overview

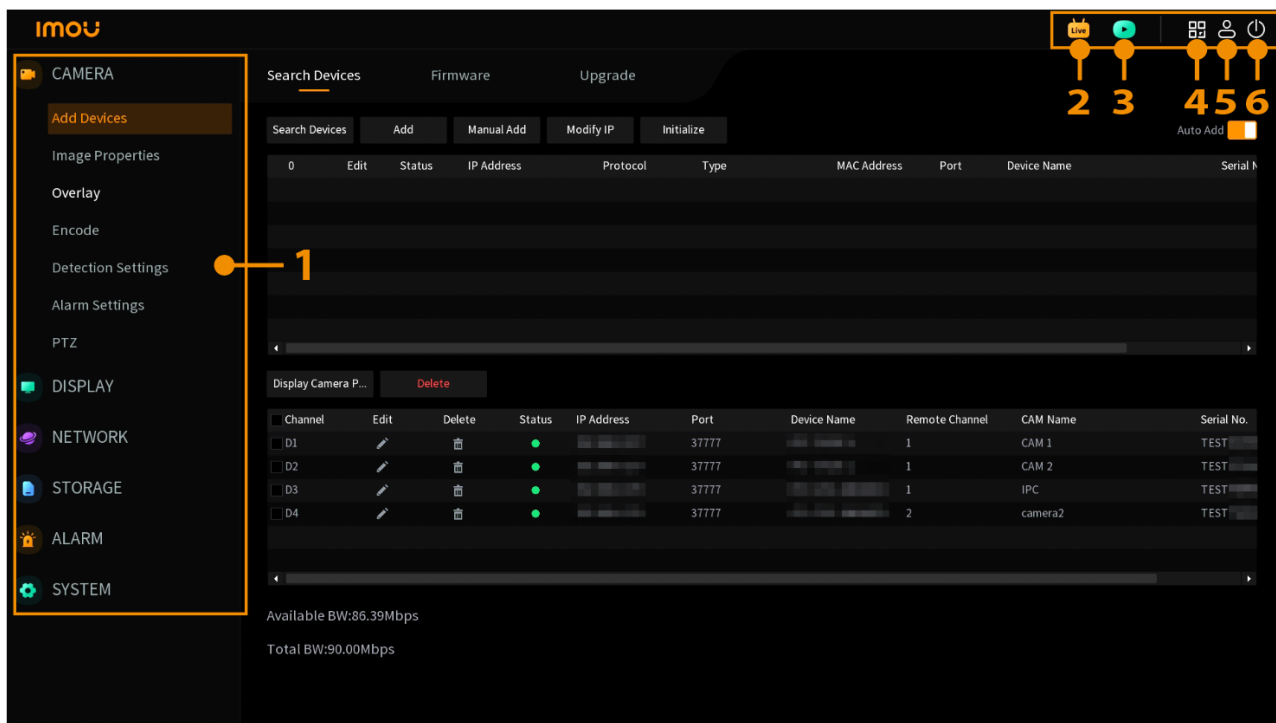



Table 5-1 Overview

No.	Item	Description
1	Settings	Click the item to unfold options .
2		View live streams. See "5.3 Live View" for details.
3		Access recorded videos. See "5.4 Playback" for details.
4		Click to display QR codes. See "5.7.3 Cloud Services" for adding the NVR to the app. <ul style="list-style-type: none"> Cellphone Client: Scan to download the Imou Life app. Net Config QR Code: Scan to add the NVR to the app.
5		Hover over the icon to show the username of the currently logged-in account.

No.	Item	Description
6		Select to logout, reboot or shut down.

5.2 Camera Settings

This section centralizes camera configurations from initial camera connection (search, initialization, adding, etc) to basic camera settings such as detection, image tuning, alarm linkage, PTZ controls, etc.





5.2.1 Add Devices

By connecting security cameras to the NVR, you will get a powerful system with live viewing, recording, event alerts, centralized management, etc. Cameras can be connected to the NVR with different methods. Basically there are auto-connection (5.2.1.1), connecting by manual searching (5.2.1.2) and manual adding (5.2.1.3).

5.2.1.1 Auto Connection

Newly added cameras will automatically connect to the NVR. If the auto-connection fails or you prefer not to wait for the process, proceed to "5.2.1.2 Manual Search" or "5.2.1.3 Manual Add" for alternative methods.

Notices Before Auto Connection

- For hardwired cameras:
 - Ensure the camera is on the same network segment as the NVR. If not, click **Search Devices** button to manually find the camera, then modify its IP settings.
 - ◇ For uninitialized cameras, initialize it first and assign a new IP as part of the setup. See "5.2.1.5 Initialize Detected Devices."
 - ◇ For initialized cameras, click , then adjust the IP settings. See "5.2.1.4 Modify IP"
- For re-added cameras (previously deleted from the NVR):
 - Auto-connection is not supported. Use "5.2.1.2 Manual Search" or "5.2.1.3 Manual Add" to add this type of cameras.
- For cameras with different usernames or passwords than the NVR:
 - In case the camera's credentials differ from NVR's, it will be marked with  once added.
 - Hovering on the  will display the error "Invalid username or password," which will also appear on this channel's live stream. You are required to click  to re-enter camera's own username and password to solve this.
- For third-party cameras:

Newly added third-party ONVIF cameras which are on the same LAN as the NVR can also be auto-connected. Once added, enter camera's own username and password by clicking  and save changes. For more connection methods, refer to question 3 in "6 FAQ" for detailed adding instructions.

Auto Connection Steps

Step 1 Right-click anywhere on the live view and navigate to **Main Menu > Camera > Add Devices > Search Devices**.



By enabling the **Auto Add** (located beside the **Initialize** tab), the cameras will be automatically discovered and connected to the NVR. Toggle it off will disable the auto-connection feature.

Figure 5-2 Start Auto Connection

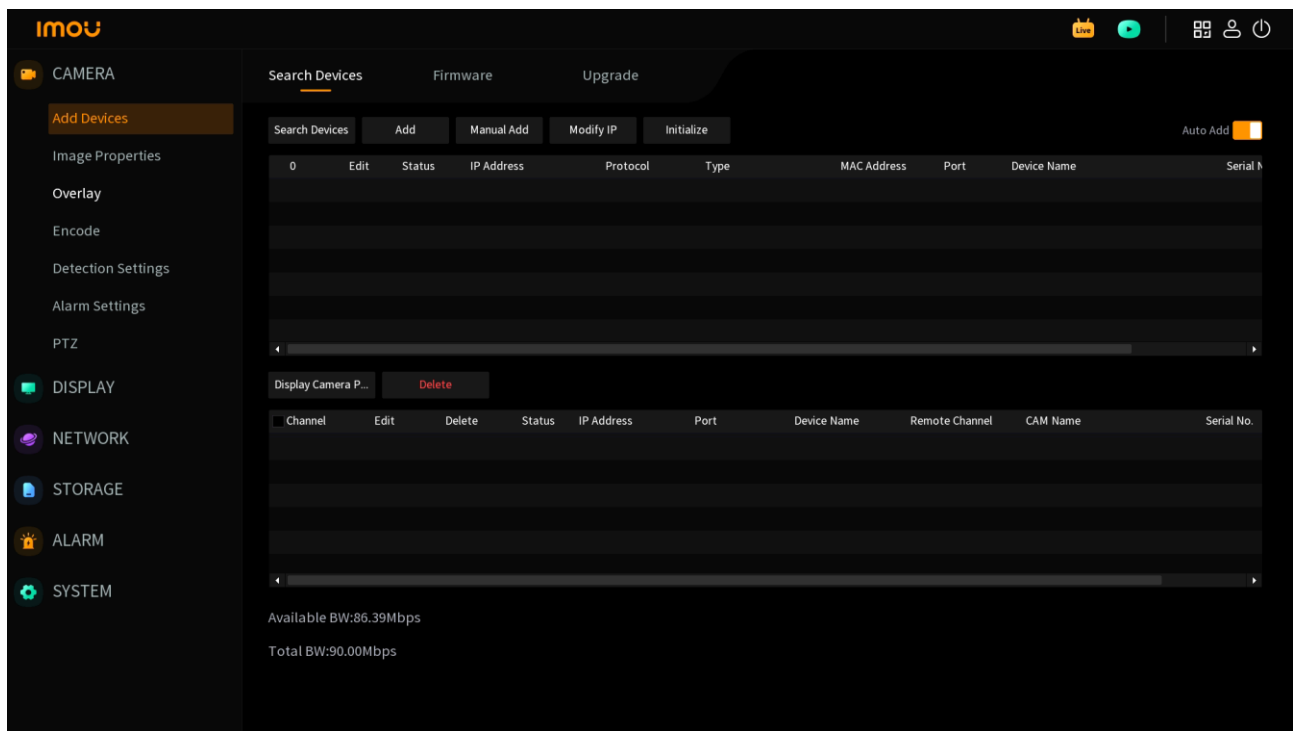

Step 2 Remain on the **Search Devices** screen. Wait until the camera successfully connects to the NVR, which will be listed in the lower pane marked with .



Auto connection will be interrupted if you exit **Search Devices** interface or click **Search Devices** or **Manual Add** button during the process.

Figure 5-3 Automatically Connected Cameras

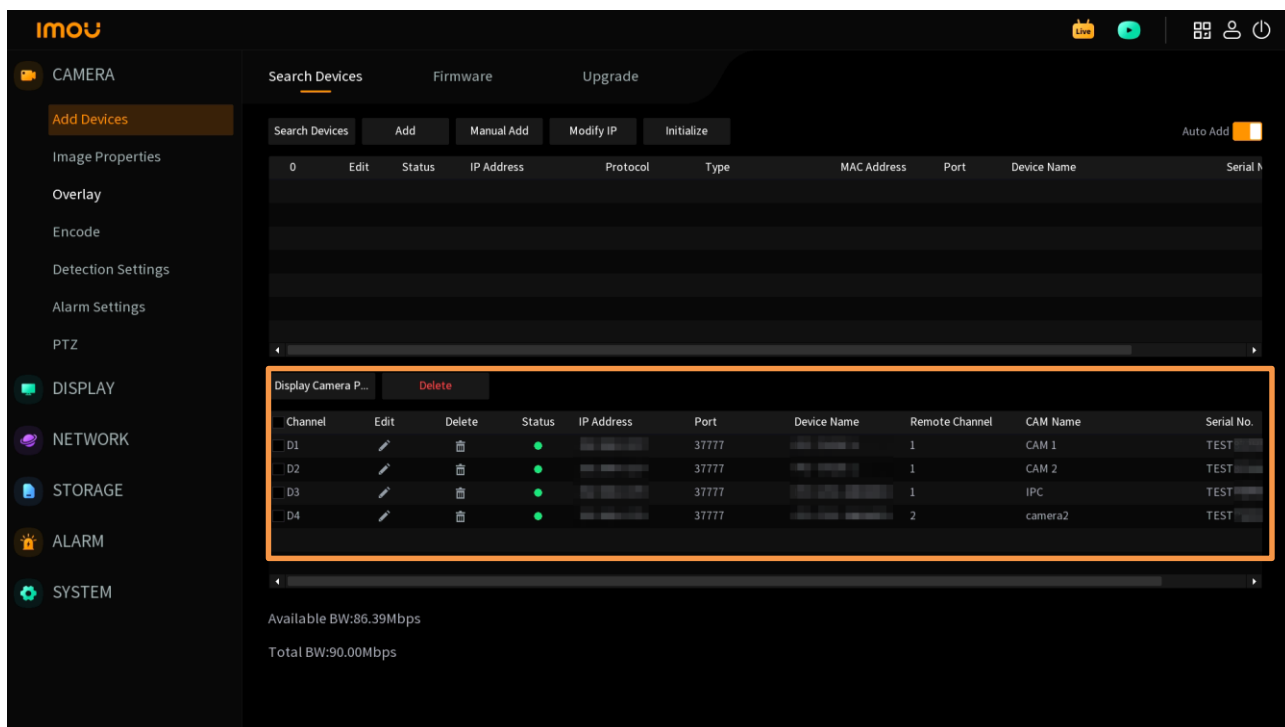







Table 5-2 Devices Connected (Lower Pane)

Item	Description
Display Camera Password	Click and then verify the NVR's password to display the passwords of all connected camera channels under the Password tab and click again to hide their passwords.
Delete	Click to delete one or multiple selected channels.
Channel	Displays the Channel ID used to mark this channel.
Edit/Delete	<ul style="list-style-type: none"> Click  to modify the information of connected devices such as username, password, etc. Click  to delete one or multiple selected channels.
Status	<ul style="list-style-type: none"> : The camera is successfully connected to the NVR. : Failed to connect the camera to the NVR.
Device Information	<p>Display the information of detected devices including IP address, port, device name, lens order of this camera, channel name and serial number.</p> <p></p> <p>To adjust the display sequence of the detected devices, click any tabs mentioned, IP Address for example, then click  near the tab to reorder.</p>

5.2.1.2 Manual Search

Add cameras by manually initiating a device search and click detected cameras to connect them to the NVR.

Step 1 Right-click on the live interface and navigate to **Main Menu > Camera > Add Devices > Search Devices**.

Step 1 Click **Search Devices** button. The detected cameras will be listed in the upper pane.



The cameras already connected will not appear in the detected list again.

Figure 5-4 Add by Manual Search

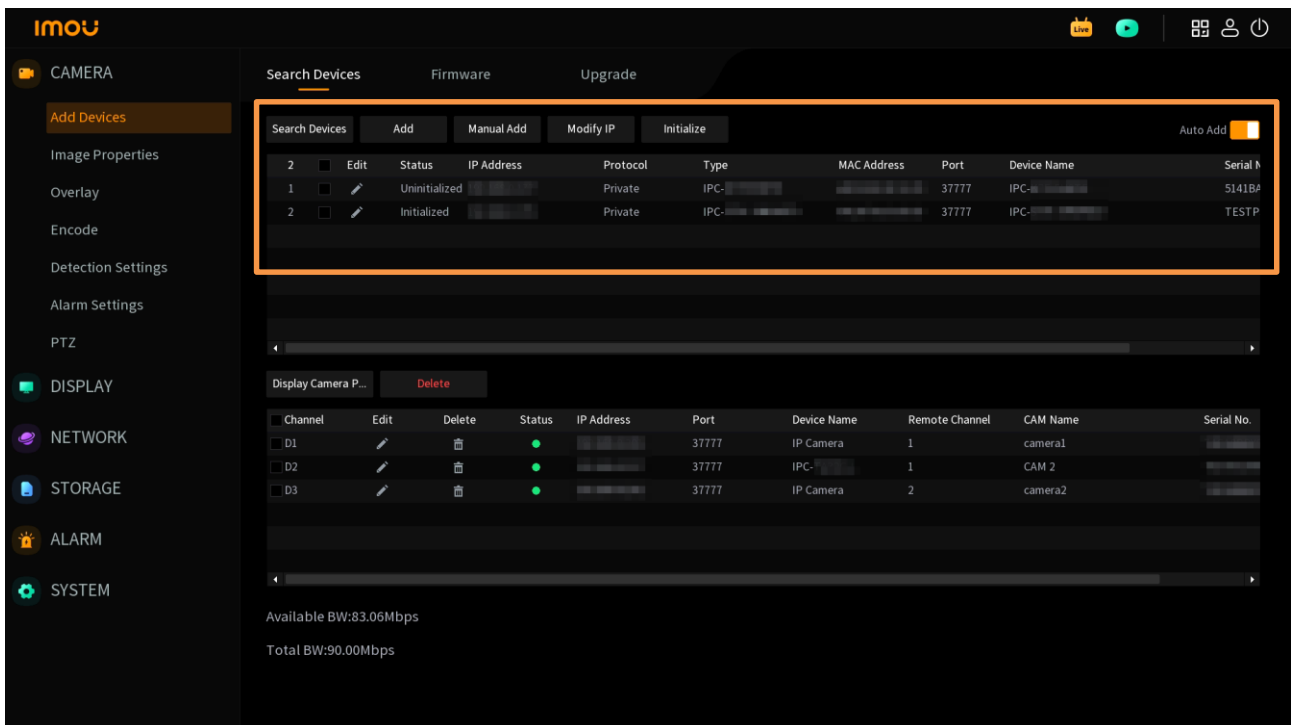







Table 5-3 Search Devices (Upper Pane)

Item	Description
Search Devices	Click to search for unconnected cameras and they will appear in the list.
Add	Tick one or multiple detected devices and click Add to connect them to the NVR.
Manual Add	Add devices to the NVR by manually configuring settings such as IP address, protocol, etc. See "5.2.1.3 Manual Add."
Modify IP	Modify IP address of one or multiple detected devices. See "5.2.1.4 Modify IP:" Only wired cameras support IP modification.
Initialize	Initialize any detected but uninitialized devices to modify their password and IP address. See "5.2.1.5 Initialize Detected Devices."
Quantity Number	The amount of detected devices.

Item	Description
Edit	Click  to modify IP settings of the selected device. See "5.2.1.4 Modify IP."  The function is exclusive to wire-connected cameras.
Status	<ul style="list-style-type: none"> ● Initialized: The detected device has been initialized. ● Uninitialized: The detected device is not initialized. Click Initialize button to start initialization.
Device Information	Display the information of detected devices including IP address, protocol, model, MAC address, port, device name and serial number.  To adjust the display sequence of the detected devices, click any tabs mentioned, IP Address for example, then click  near the tab to reorder.

Step 2 To add the cameras, double-click the discovered device or tick one or multiple devices and click **Add**. The connected cameras will be listed on the lower pane. Marked by  means a successful connection.



- The functionality explanation of the lower pane (connected devices) can be found in "Table 5-2 Devices Connected (Lower Pane)."
- If the cameras are not initialized, it should go through initialization before it can be added to the NVR. See "5.2.1.5 Initialize Detected Devices."

5.2.1.3 Manual Add (Information Entry)

Add cameras to the NVR by manually entering their details like IP address, protocol, password, etc. Recommended when your camera uses Onvif protocol or you're aware of the input information or the camera failed to be detected.

Step 1 Right-click on the live interface and navigate to **Main Menu > Camera > Add Devices > Search Devices**.

Step 2 Click **Manual Add** on the upper pane and configure parameters.







Step 3 Click **OK** and the device will be listed in the lower pane as connected devices. Marked by  means a successful connection.

Figure 5-5 Manual Add

Table 5-4 Manual Add

Item	Description
Channel	Select the channel ID to mark this channel.
Protocol	Select from Private and Onvif . Generally, Imou cameras use Private protocol and cameras across brands use Onvif protocol.
IP Address	Enter the IP address of the camera to be connected.
TCP Port	Enter the TCP port value, which is 37777 by default.  This setting is necessary when Protocol is set to Private .
RTSP Port	Select from Self-adaption and Customized . Enter the RTSP port value if it is set to Customized .  This setting is necessary when Protocol is set to Onvif .
HTTP Port	Enter the HTTP port value, which is 80 by default.  This setting is necessary when Protocol is set to Onvif .
Username	Enter the username of the camera to be connected.
Password	Enter the password of the camera to be connected.

Item	Description
Channel No.	Enter the total channel numbers of this camera. Click Setting to select its channels you want to connect.  This setting is necessary when Protocol is set to Onvif .
Encrypt	Turn on Encrypt will encrypt the data being transmitted.  <ul style="list-style-type: none"> This setting is necessary when Protocol is set to Onvif. The encryption works only when the Onvif-protocoled camera finishes Onvif encryption settings. By enabling Encrypt, RTSP Port will be deactivated and the HTTP converts to HTTPS (default port: 443, customizable if needed).

5.2.1.4 Modify IP

In case you need to modify IP settings of cameras to be connected, follow steps below.



Only initialized hardwired cameras can modify their IPs.

Step 1 Right-click anywhere on the live view and navigate to **Main Menu > Camera > Add Devices > Search Devices**.

Step 2 Select one or multiple detected devices and click **Modify IP**.

Figure 5-6 Modify IP

Step 3 Select IP assignment mode.

- **DHCP:** IP address, subnet mask and default gateway will be automatically assigned; no manual input required.
- **Static:** Manually input IP address, subnet mask, default gateway and incremental value.



The incremental value field allows batch configuration of multiple devices - the system automatically generates sequential IPs by increasing the fourth octet (e.g., starting from 192.168.1.100 with an increment of 5 would create 192.168.1.105, 192.168.1.110, etc.).

Step 4 Enter the username and password of the modified device to verify.



For multiple IP configuration, ensure the cameras have the same usernames and passwords.

Step 5 Click **OK** to save settings and the IP address will be refreshed in the list.



If the IP address does not update, click **Search Devices** to manually detect this camera, and its IP address will be refreshed.

5.2.1.5 Initialize Detected Devices

Devices need to be initialized before connecting to the NVR. During this process, password and IP settings can be adjusted.

Step 1 Right-click anywhere on the live view and navigate to **Main Menu > Camera > Add Devices > Search Devices**.

Step 2 Click **Search Devices**. Select uninitialized devices, then click **Initialize**.

Step 3 (Optional) Ticking **Use the 'admin account password' as this IPC's password** will automatically apply the NVR's admin password to this camera and you can proceed directly to step 4. Unchecking this option requires you to create a new password for this camera.

Figure 5-7 Initialize Devices – Use NVR's Password

The screenshot shows a dark-themed 'Initialize' screen. At the top left, the word 'Initialize' is displayed in white. Below it, there is a single option with a checked checkbox: 'Use the 'admin account password' as this IPC's password.' In the bottom right corner, there is an orange button labeled 'Next'.

Figure 5-8 Initialize Devices – Create Password

The screenshot shows a dark-themed 'Initialize' screen. At the top left, the word 'Initialize' is displayed in white. Below it, there is an unchecked checkbox option: 'Use the 'admin account password' as this IPC's password.' Below this is a horizontal separator line. Underneath, there are three fields: 'Username' with the value 'admin', 'Password' with an empty input box, and 'Confirm Password' with an empty input box. To the right of the password fields, there is a text description: 'Password length is between 8 and 32 characters, and it includes at least two types from numbers, letters and general characters (Any characters except ' '; : &)'. In the bottom right corner, there is an orange button labeled 'Next'.

Table 5-5 Initialize Devices – Create Password

Item	Description
Username	The default is admin .
Password	The password should be 8-32 characters long and contain at least two types from numbers, letters or symbols (except ' " ; : &). Follow the strength meter to create a high-security password.
Confirm Password	

Step 4 Select IP assignment mode.

- **DHCP:** IP address, subnet mask and default gateway will be automatically assigned; no manual input required.
- **Static:** Manually input IP address, subnet mask, default gateway and incremental value.



- The incremental value field allows batch configuration of multiple devices - the system automatically generates sequential IPs by increasing the fourth octet (e.g., starting from 192.168.1.100 with an increment of 5 would create 192.168.1.105, 192.168.1.110, etc.).
- For batch initialization, the IP addresses will be switched into the same network segment.

Step 5 Click **Next** and the initialization starts. Wait until the process finishes, then click **OK** to exit.

5.2.1.6 Firmware

Check connected cameras' information including channel IDs, IP addresses, protocols, model, firmware versions and serial numbers. For details, access **Main Menu > Camera > Add Devices > Firmware**.

Figure 5-9 Firmware

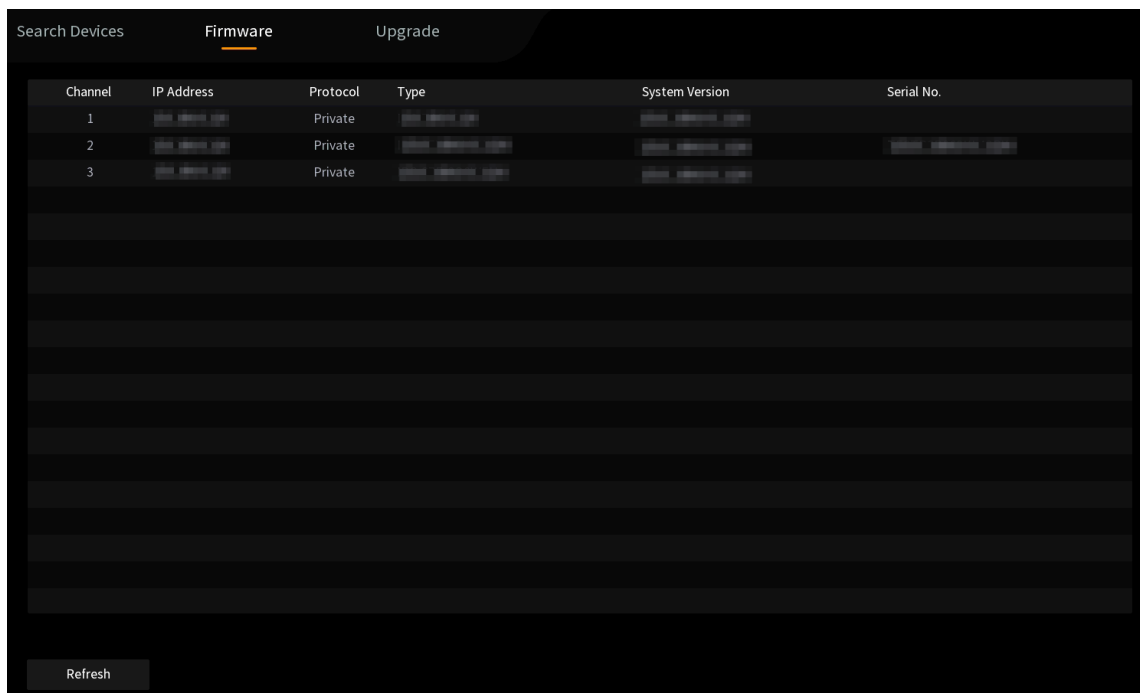

5.2.1.7 Upgrade

Upgrade the firmware of connected cameras using either online upgrade or local file upgrade.



- Do not disconnect the power of all the devices during upgrade.
- Ensure the camera to be upgraded is online.
- Camera upgrades via the NVR are limited to private protocol models; ONVIF cameras are not supported.

Step 1 Right-click anywhere on the live view and navigate to **Main Menu > Camera > Add Devices > Upgrade**.

Figure 5-10 Upgrade Firmware

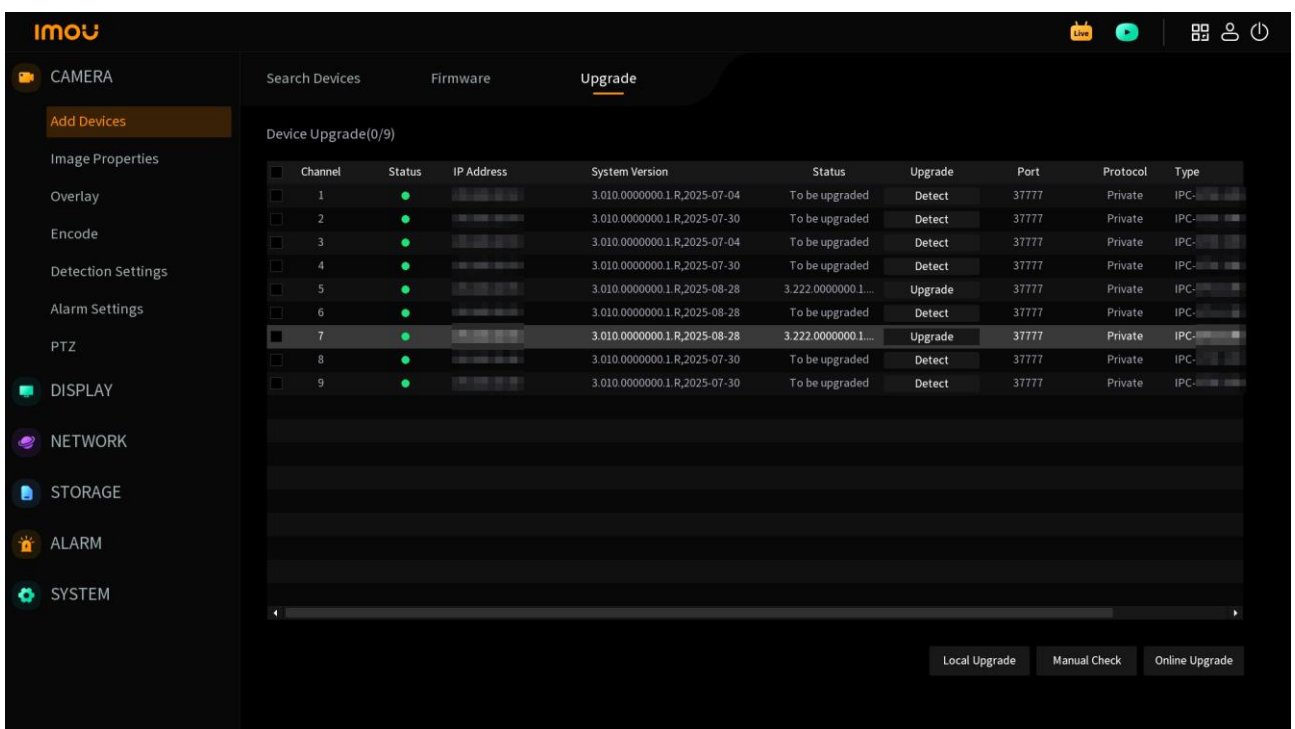

Step 2 Upgrade the firmware of connected cameras online or through local file.

- Method 1: Online Upgrade



Ensure the NVR has correctly connected to the active Internet.

- 1) Select an online device and click **Detect** on the right side, or tick its checkbox and then click **Manual Check** at the bottom of the interface.
- 2) Select a device with an available update, then click **Upgrade** beside or click **Online Upgrade** at the bottom.
- 3) Confirm the message to start the upgrade.
Upon successful completion, the **Status** tab will display a confirmation message.

- Method 2: Local File Upgrade

- 1) Insert a USB device containing the firmware upgrade file.
- 2) Select the desired device and click **Local Upgrade**.
- 3) Select the upgrade file on the pop-up window.
- 4) Click **OK** to confirm and begin the upgrade.

Upon successful completion, the **Status** tab will display a confirmation message.

5.2.2 Image Properties

It provides essential controls to optimize video quality like adjusting WDR, flipping camera angles and night vision mode.



The settings may vary by camera models. Configuration options depend on camera's capabilities with some may not be configurable.

Step 1 Right-click on the live interface, navigate to **Main Menu > Camera > Add Devices > Image Properties**.

Figure 5-11 Image Properties

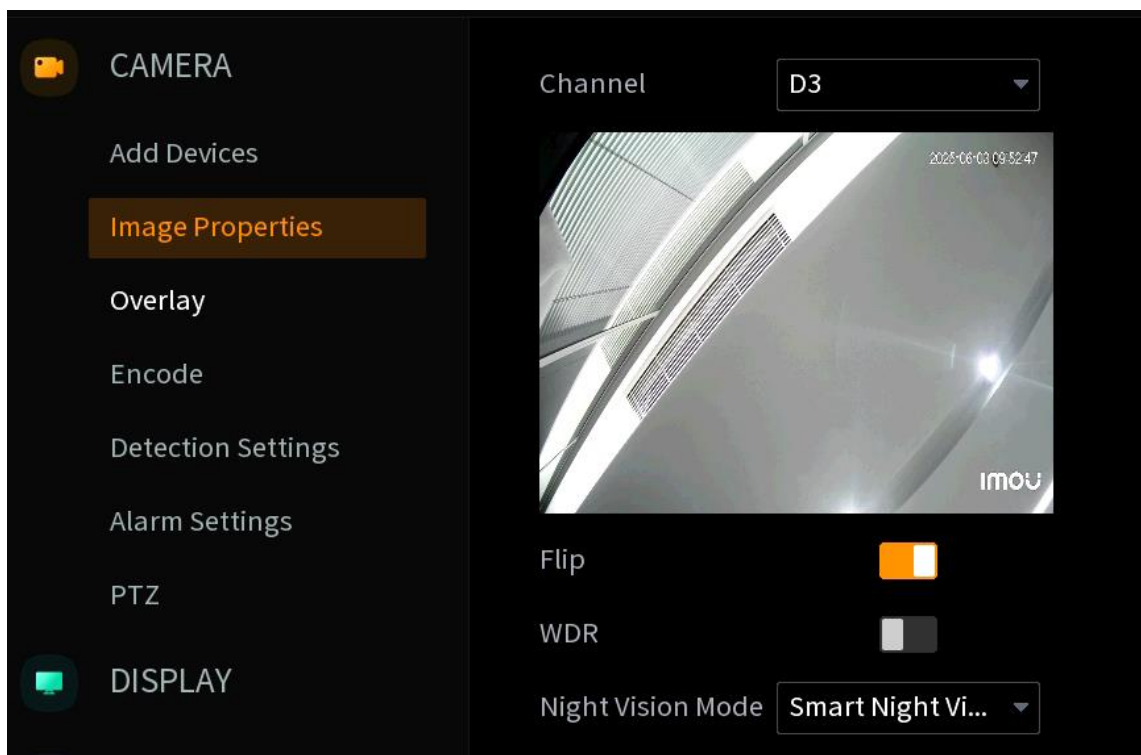

Step 2 Configure the settings as needed, then click **Apply**.

Table 5-6 Image Properties

Item	Description
Channel	Select a channel to configure.
Live Stream	The live stream of the selected channel which directly display the visual effects of your configuration changes.
Flip	Toggle it on to rotate the live feed image by 180 degrees. Recommended when your camera is installed upside down.
WDR	Balances light/dark contrasts, preventing overexposed highlights and underexposed shadows for optimal clarity in high-contrast scenes.
Night Vision Mode	Night vision technology enhances visibility in low-light or dark conditions using different methods.

Item	Description
	<ul style="list-style-type: none"> ● Smart Night Vision: Uses IR for black-and-white viewing but automatically switches to color when motion triggers the spotlight. ● Color Night Vision: Keeps footage in full color by using spotlights even in complete darkness. ● IR Night Vision: Relies solely on infrared to generate black-and-white videos. ● Night Vision Off: Disables all enhancements for ambient-light-dependent video.

5.2.3 Overlay

It allows you to customize the information displayed on your live camera feeds including timestamp, channel name, etc.

Step 1 Right-click on the live interface and navigate to **Main Menu > Camera > Overlay**.

Figure 5-12 Overlay

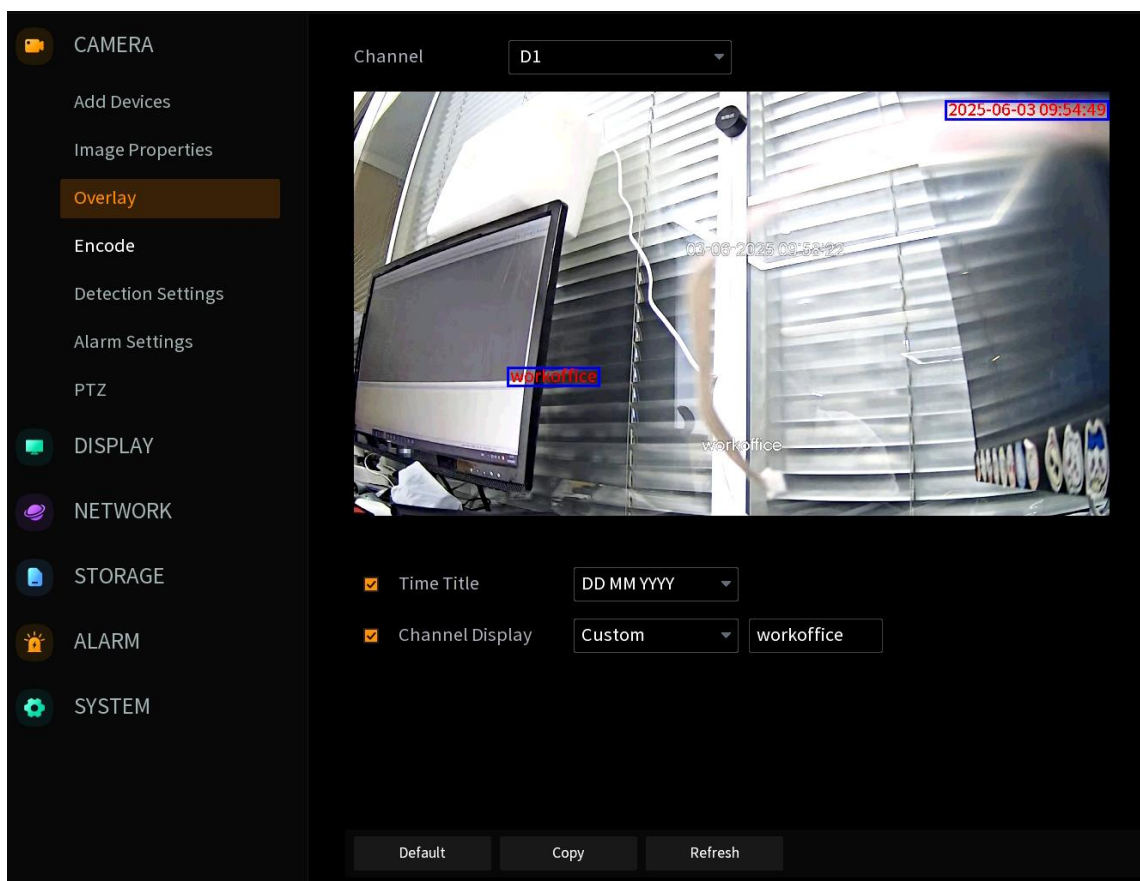

Step 2 Configure the settings as needed, then click **Apply**.

Table 5-7 Overlay

Item	Description
Channel	Select a channel to configure.

Item	Description
Live Stream	The live stream of the selected channel which directly display the visual effects of your configuration changes.
Time Title	Displays timestamp on the live feed of selected channel with adjustable format and position (default: upper-right corner, drag to reposition)
Channel Display	Displays either the brand logo (fixed place) or a custom channel name in the bottom-right corner (drag to reposition).
Default	Resets all overlay settings to original factory defaults.
Copy	Replicate the current overlay settings to other channels.
Refresh	Refresh the interface.

5.2.4 Encode

Adjust camera settings such as resolution and FPS (Frame per Second) for optimizing video quality.

Step 1 Right-click on the live interface and navigate to **Main Menu > Camera > Encode**.

Figure 5-13 Encode

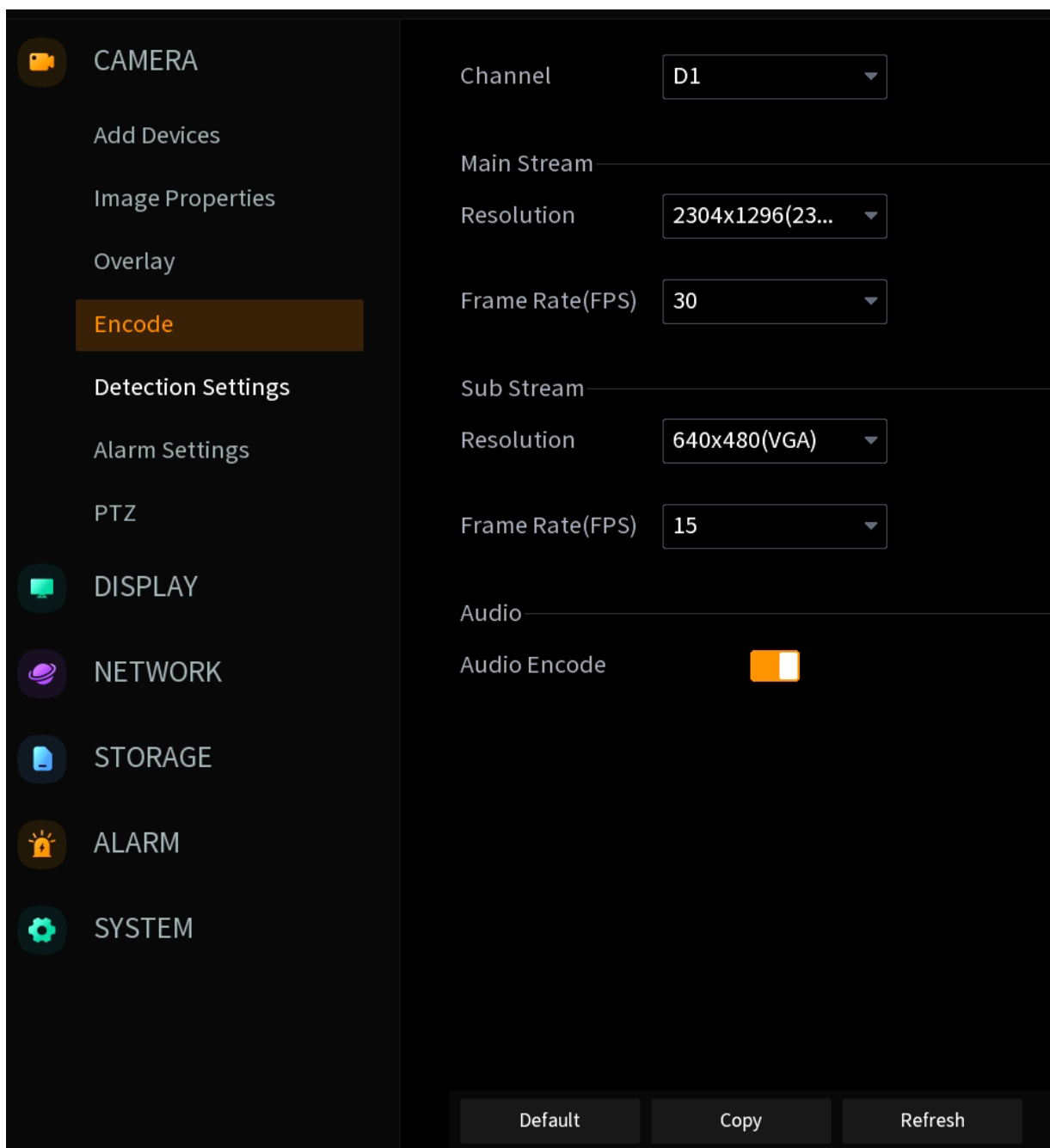

Step 2 Configure the settings as needed, then click **Apply**.

Table 5-8 Encode

Item	Description
Channel	Select a channel to configure.
Resolution	Select resolution as needed. Higher resolution means more details in videos or images, but also higher bandwidth/storage requirements.
Frame Rate (FPS)	Select FPS as needed. Higher FPS allows the camera to capture more frames per second, resulting in smoother video but increased bandwidth and storage demands.
Audio Encode	Toggle it off will mute all sound in the live and recorded videos.

Item	Description
Default	Resets all encode settings to original factory defaults.
Copy	Replicate the current encode settings to other channels.
Refresh	Refresh the interface.

5.2.5 Detection

Customize detection settings by type, sensitivity, areas and schedules.



The settings may vary by camera models. Configuration options depend on camera's capabilities with some may not be configurable.

Step 1 Right-click on the live interface and navigate to **Main Menu > Camera > Detection Settings**.

Figure 5-14 Detection

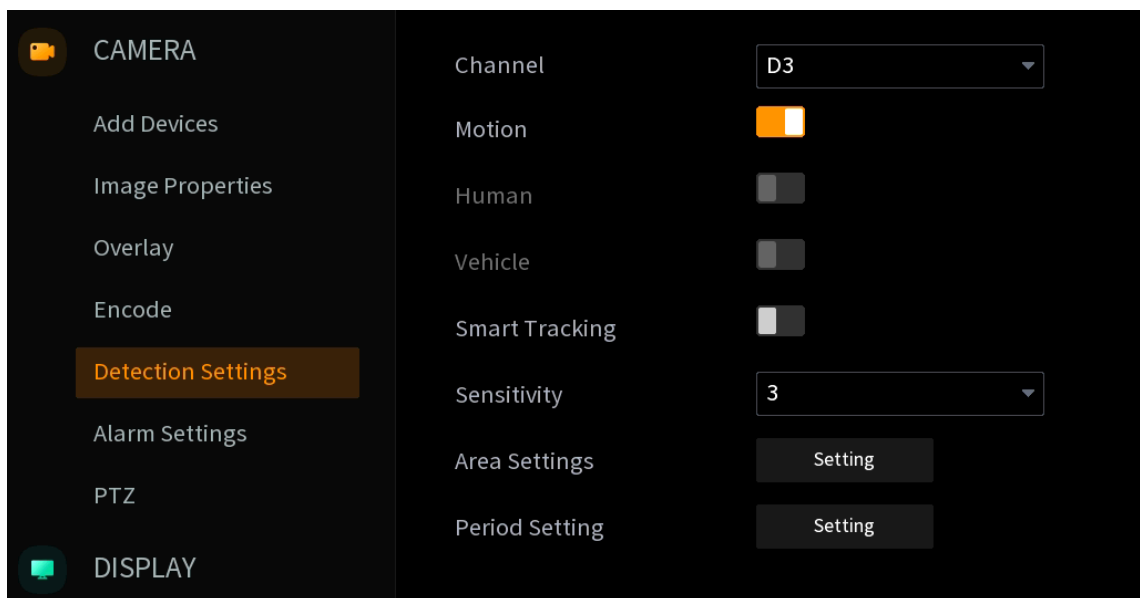

Step 2 Select a channel to configure.

Step 3 Set detection types to trigger event-based recording.



Event recording requires at least one detection type to be enabled. If none are active, in the default factory settings, the system performs continuous recording.

- **Motion:** Enable to detect general movements.
- **Human:** Enable to specifically detect people.
- **Vehicle:** Enable to specifically detect vehicles.
- **Smart Tracking:** Enable to make cameras with pan-tilt capabilities automatically follow the detected objects until the object moves outside its field of view. Requires at least one detection type above to be active.

Step 4 Set detection sensitivity from 1 (the lowest) to 5 (the highest).



Higher sensitivity may increase the number of alerts and the event recordings, but may cause more false detections as well.

Step 5 Draw detection areas.

Click **Setting** next to **Area Setting**. Currently there are two types of detection area setting.

- Type One — Adjust Handles

Figure 5-15 Draw Detection Areas (Type One)

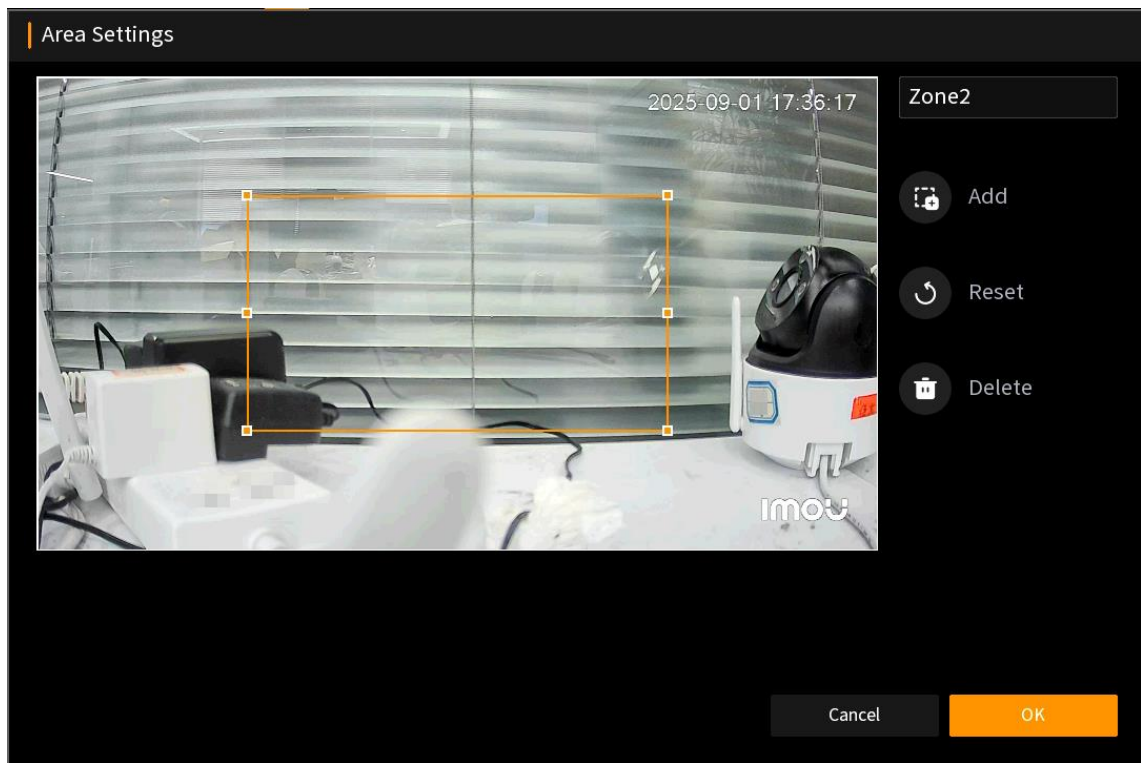



- 1) Click anywhere on the live feed to activate the default full-screen detection zone (marked by an orange frame with 6 resize corner/edge handles).
 - 2) Customize the detection areas.
 - ◇ **Add:** Click  to add a new detection area (max.3).
 - ◇ **Name:** Select a zone, then enter its name in the upper-right text box.
 - ◇ **Adjust:** Select a zone. Click and drag any of the six handles to resize it. Drag to reposition the zone for precise detection coverage.
 - ◇ **Reset:** Click  to restore all detection areas to default.
 - ◇ **Delete:** Select a zone, then click  to remove it.
 - 3) Click **OK** to save settings.
- Type Two – Draw Grids

Figure 5-16 Draw Detection Areas (Type Two)



- 1) Click or drag to edit detection areas.
 - ◇ **Remove detection zones:** By default, the entire screen is set as a detection zone, covered by orange grids. Click or drag on the orange grids to convert these areas to non-detection with transparent grids.
 - ◇ **Set detection zones:** Click or drag across transparent grids to re-enable detection for these areas, indicated by orange grids.
- 2) Right click to exit once completed.

Step 6 Set detection schedules.

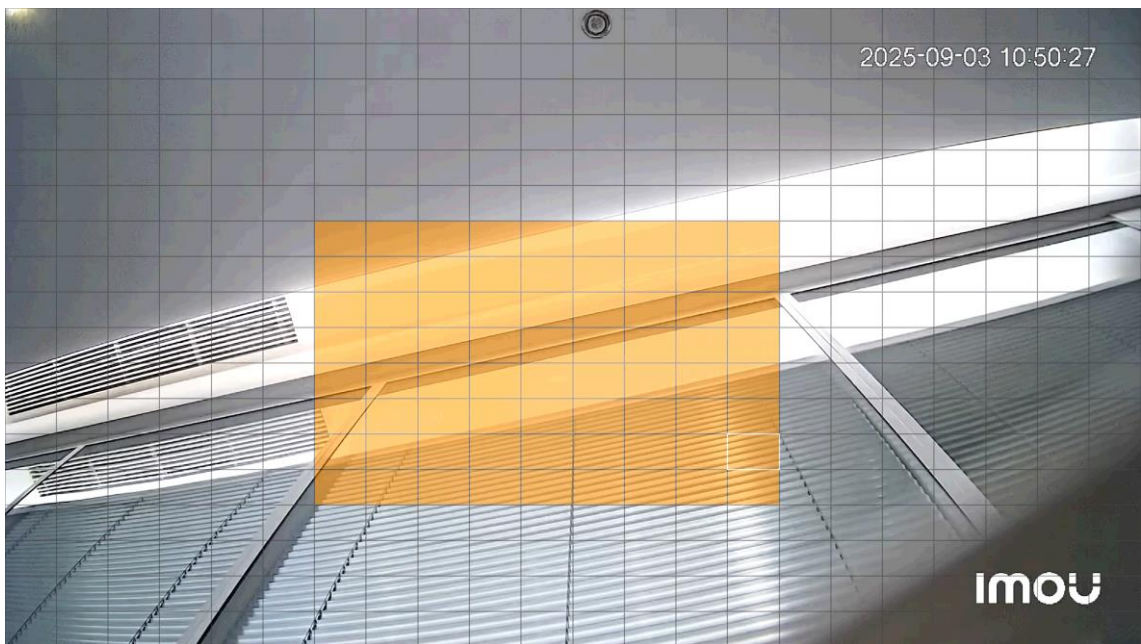
Click **Setting** next to **Period Setting**. Use the drawing or editing modes to define your schedules.

- Type One — Draw Mode (Visual Timeline Editing)

Figure 5-17 Draw Detection Periods

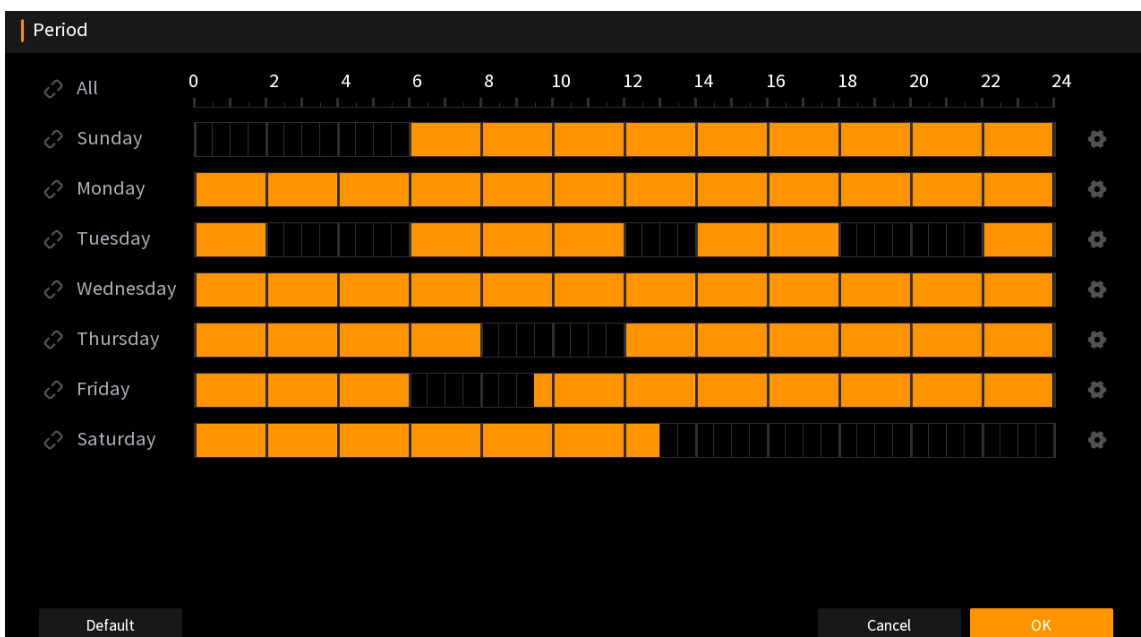





- ◇ **Create detection periods:** Left-click or drag on the timeline to create up to five detection periods (shown as orange block), each divided into 30-minute interval.
- ◇ **Remove detection periods:** Click or drag the existing period to remove or edit this period.
- ◇ **Synchronous actions:**
 - i. Click  next to **All** – symbols of all days will change to . Adjust settings for one day and changes will apply to all days automatically.
 - ii. Click  next to individual days – their symbols will change to . Adjust settings for selected days and changes will sync only to the marked days.
- ◇ **Restore defaults:** Click **Default** to reset to non-stop 24/7 detection.
- Type Two — Edit Mode (Precise Time Entry)
 - 1) Click  icon next to any date.

Figure 5-18 Precise Period Entry



- 2) Enter up to five exact time periods, then check the box to make it take effect.

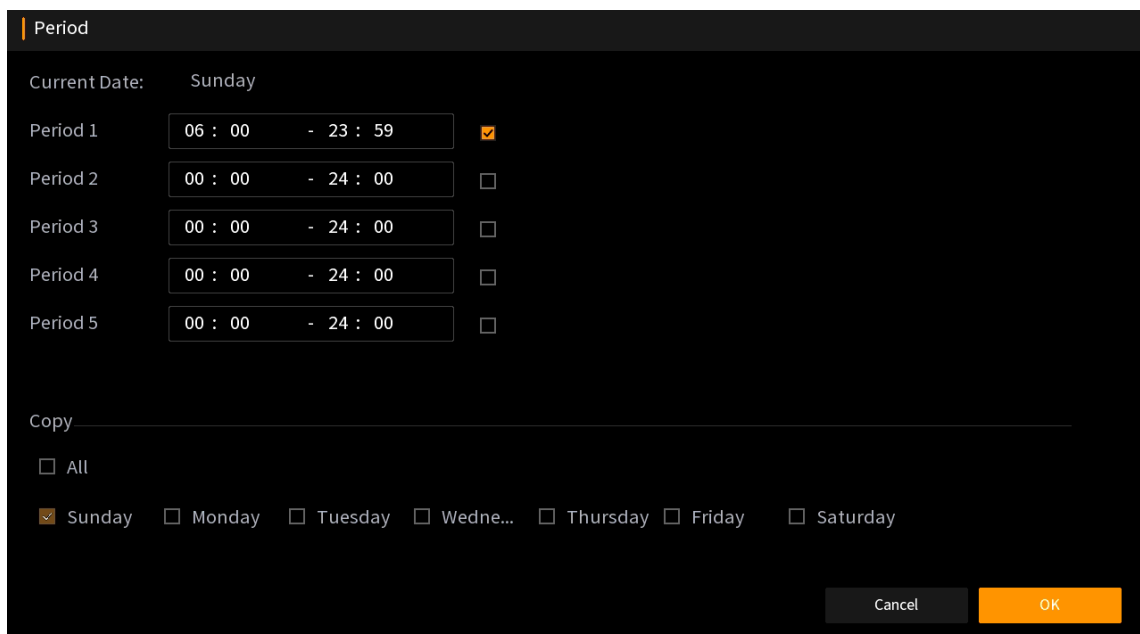

The period already defined in the drawing mode will be marked a tick beside the time entry box. Uncheck the box will remove the preset time period.

- 3) (Optional) Click **Copy** to duplicate the current settings to the entire week (select **All**) or partial dates (select specific dates).
- 4) Click **OK**.

Step 7 Click **OK** to finish period settings.

Step 8 Click **Apply** to make detection settings effective.

5.2.6 Alarm

Configures how the camera reacts (light or sound alerts, for example) when the alarm is triggered within detection periods.



- The settings may vary by camera models. Configuration options depend on camera's capabilities with some may not be configurable.
- To trigger the camera actions, ensure the required detection type is enabled in detection settings. See "5.2.5 Detection."

Step 1 Right-click on the live interface and navigate to **Main Menu > Camera > Alarm Settings**.

Figure 5-19 Alarm

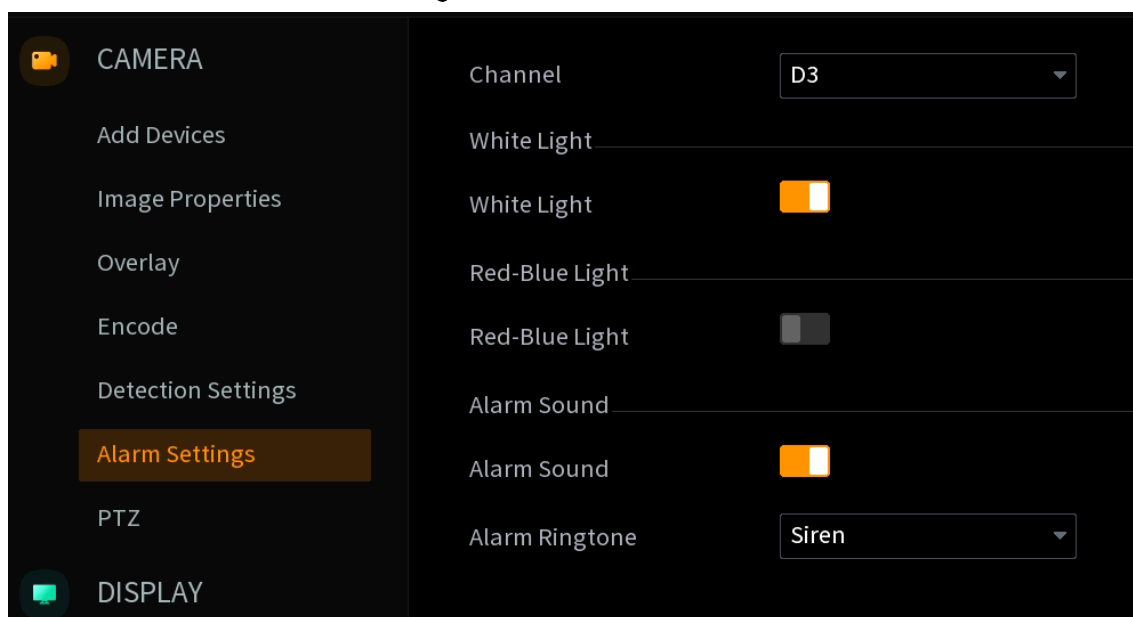

Step 2 Configure the settings as needed, then click **Apply**.

Table 5-9 Alarm

Item	Description
Channel	Select a channel to configure.
White Light	Enable to automatically activate the spotlight when specified detections are identified.
Red-Blue Light	Enable to automatically activate the red-blue light when specified detections are identified.
Alarm Sound	Enable to automatically activate the alarm sound when specified detections are identified.
Alarm Ringtone	Select the alarm sound. The default siren is preloaded; additional custom tones must be configured in the Imou Life app before they are available in NVR settings. Click Refresh to synchronize newly added sounds to the NVR after configuration.

5.2.7 PTZ

Deploy automated movements for your pan-and-tilt cameras with customizable cruise routines. Define a detection path by setting the patrol pattern, moving intervals, schedules, positions and more to ensure systematic coverage as needed.

Step 1 Right-click on the live interface and navigate to **Main Menu > Camera > PTZ**.

Figure 5-20 PTZ

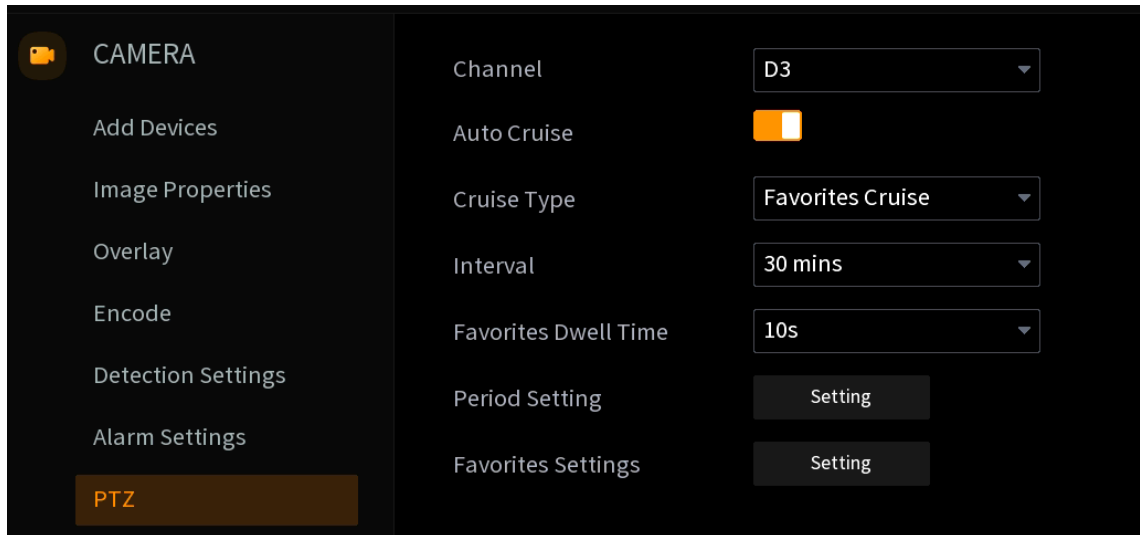

Step 2 Select a channel to configure.

Step 3 Turn on **Auto Cruise** to enable automatic camera movement with selected cruise type.

Step 4 Select the **Cruise Type**.

- **Panoramic Cruise:** The camera automatically rotates by 360 degrees for complete area coverage, pausing at 6 evenly spaced points for 10 seconds each. Further setups, see "Step 5 and Step 7."
- **Favorites Cruise:** The camera automatically tours through preset positions in sequence. Further setups, see from step 5 to 8."

Step 5 Select **Cruise Interval** - the pause time between each cycle when the camera repeats its panoramic or favorites cruise pattern again.

Step 6 (For **Favorites Cruise** only) Select **Favorites Dwell Time** – the duration that the camera remains at each preset position before moving to the next.

Step 7 Set activation periods for the selected cruise pattern.

Click **Setting** next to **Period Setting**. Use the drawing or editing modes to define your schedules.

- Type One — Draw Mode (Visual Timeline Editing)

Figure 5-21 Draw Auto-Cruise Periods

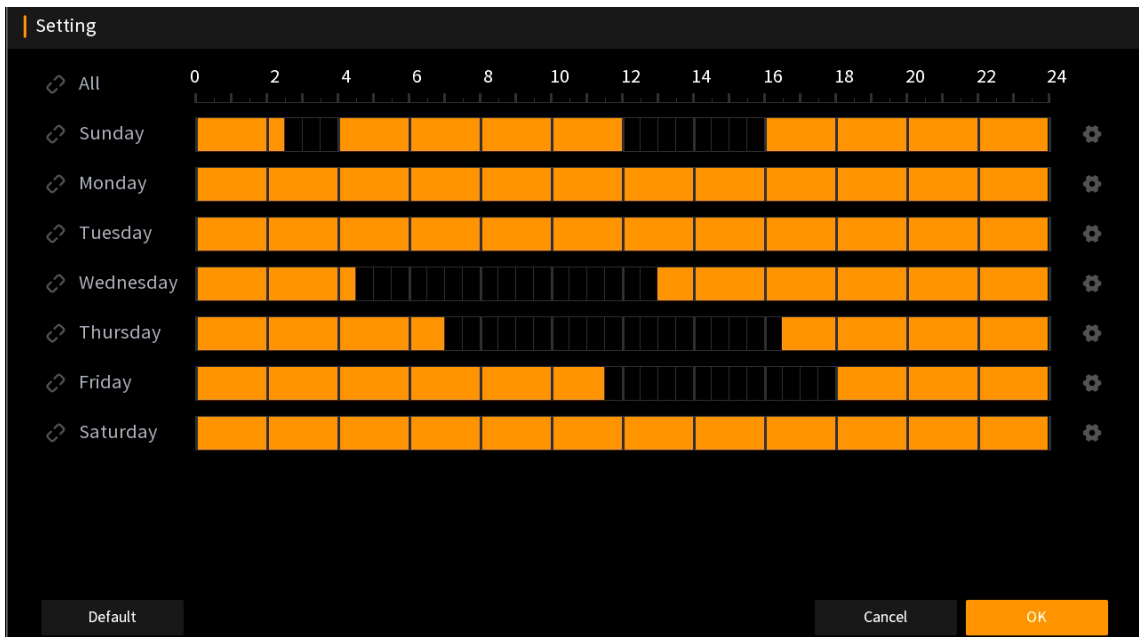





- ◇ **Create auto-cruise periods:** Left-click or drag on the timeline to create up to five auto-cruise periods (shown as orange block), each divided into 30-minute interval.
- ◇ **Remove auto-cruise periods:** Click or drag the existing period to remove or edit this period.
- ◇ **Synchronous actions:**
 - i. Click  next to **All** – symbols of all days will change to . Adjust settings for one day and changes will apply to all days automatically.
 - ii. Click  next to individual days – their symbols will change to . Adjust settings for selected days and changes will sync only to the marked days.
- ◇ **Restore defaults:** Click **Default** to reset to non-stop 24/7 detection.
- Type Two — Edit Mode (Precise Time Entry)
 - 1) Click  icon next to any date.

Figure 5-22 Precise Period Entry



- 2) Enter up to five exact time periods, then check the box to make it take effect.

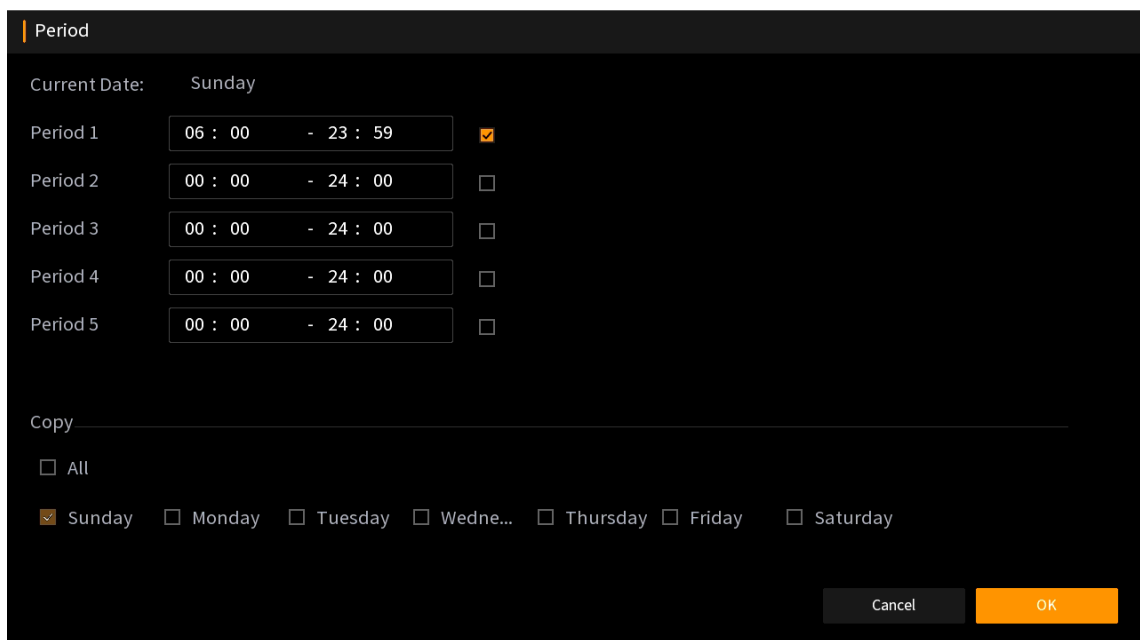

The period already defined in the drawing mode will be marked a tick beside the time entry box. Uncheck the box will remove the preset time period.

- 3) (Optional) Click **Copy** to duplicate the current settings to the entire week (select **All**) or partial dates (select specific dates).
- 4) Click **OK**.
- 5) Click **OK** to finish period settings.

Step 8 (For **Favorites Cruise** only) Set preset positions for **Favorites Cruise** to perform.

- 1) Click **Setting** next to **Favorites Settings**.

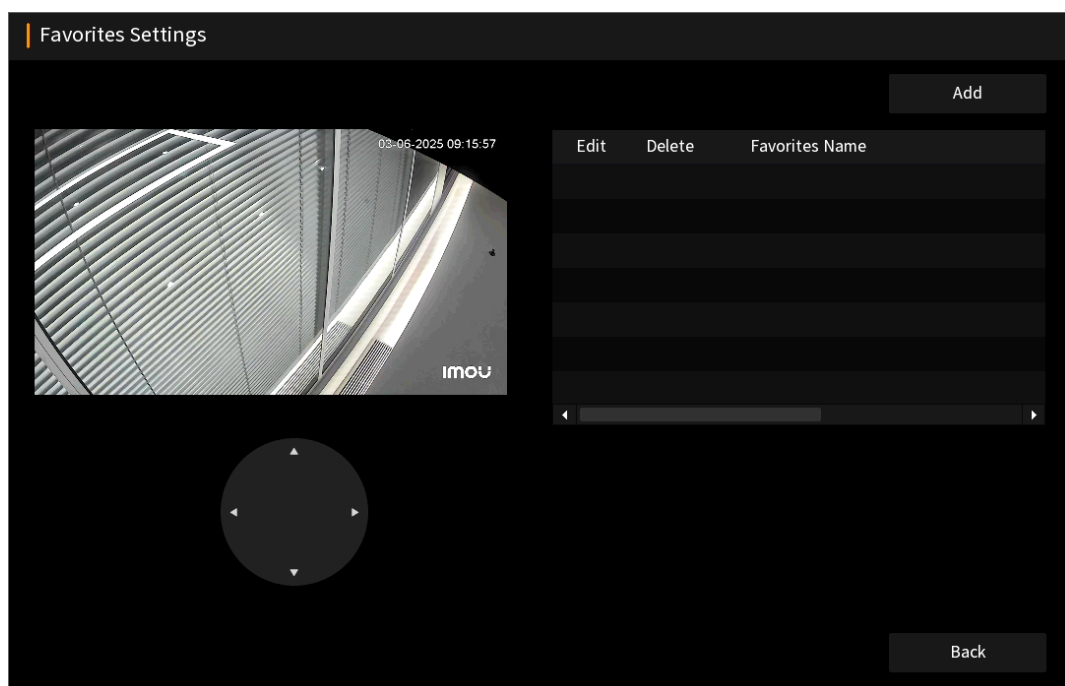

Figure 5-23 Favorites Cruise Position

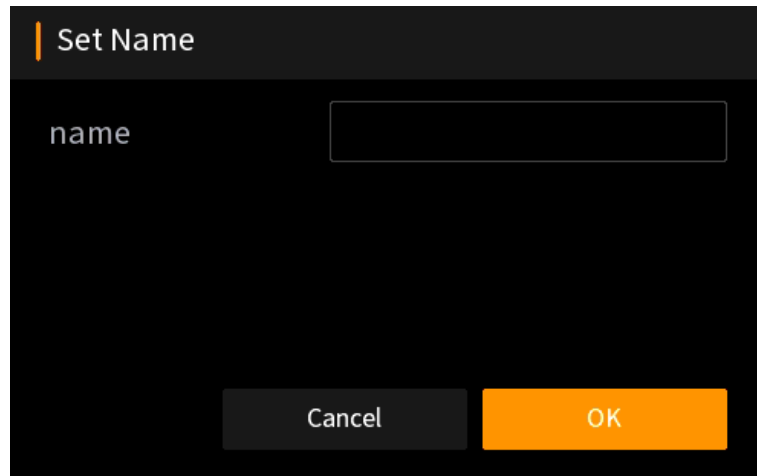

- 2) Use the arrow pad to pan/tilt the camera, checking the live feed to align the view you want.
- 3) Click **Add** at the top-right. Enter the name for the preset position, then click **OK**.

Figure 5-24 Name the Position



- Rename preset: Click  to modify the name of preset position.
 - Delete preset: Click  to delete this preset position.
- 4) Repeat previous steps to create additional positions (max 6).



The camera will cycle through preset positions in the order you saved them.

- 5) Click **Back** to exit.

Step 9 Click **Apply** to make settings effective.

5.3 Live View

This section displays real-time video streams from all connected cameras, where you can operate camera features, right-click on anywhere to access the overall settings menu, etc.

5.3.1 Interface Overview

Upon login, the system displays real-time video streams from all connected cameras in a multi-channel layout.

Figure 5-25 Live Stream Display

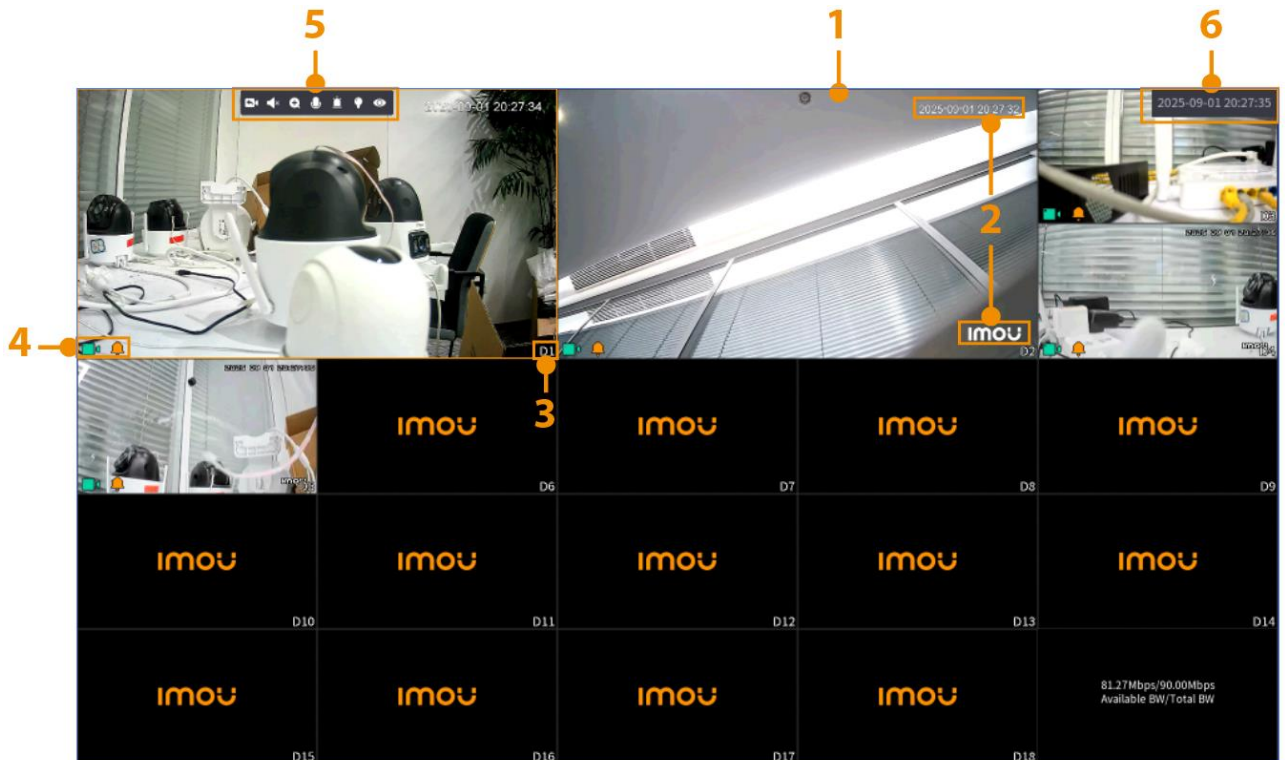



Table 5-10 Live Stream Display

No.	Item	Description
1	Live Stream	Real-time video feeds from connected channels, which can be displayed in multi-view layouts.
2	Overlay Information	Configurable on-screen text including timestamp and channel name that is adjustable in "5.2.3 Overlay."
3	Channel ID	Unique identifier for the channel (e.g., D + digital, D1).
4	Status Icons	<ul style="list-style-type: none"> : Video recording is in progress. : An event is detected.
5	Channel Toolbar	Hover on the top-center of a live feed to reveal the toolbar. Click an icon for quick actions. For details, see "5.3.4 Channel Toolbar."
6	System Time	Displays system time fixed on the upper-right corner.

5.3.2 Camera Connection Shortcut

Step 1 On the live interface, left-click **+** on any unconnected channel tiles.

Figure 5-26 Camera Connection Shortcut



Step 2 The interface will jump to device adding page. Then follow "5.2.1 Add Devices" to connect cameras to the NVR.

5.3.3 Mouse Operations for Live View

This section explains how to control live streams using mouse actions, including zooming, panning, and switching views in different layout modes.

Digital Zoom:

- Zoom in/out: Scroll the mouse wheel over a live stream.
- Pan: Click and drag to move around the zoomed view.
- Reset: Right-click to restore to the original view.

View Switching:

- For 4/9/10/ 16/18-view layouts
Double-click a live feed for full screen mode. Double-click again to recover.
- For 8-view layout
Double-click a small view to swap it with the main large view.
- For single view
Double-click to revert to the last-used multi-view layout.

5.3.4 Channel Toolbar

The toolbar offers real-time channel controls for instant playback, audio, zoom, and security functions. Hover on the top-center of a live feed to reveal the toolbar.



The settings may vary by camera models. Configuration options depend on camera's capabilities with some may not be configurable.

Figure 5-27 Channel Toolbar (1)





Figure 5-28 Channel Toolbar (2)



Table 5-11 Channel Toolbar

Item	Description
	Replays the last 5-60 minutes' video recordings of the selected channel. Time range is adjustable in System Settings > Basic Configuration . To exit, right-click on the video clip or click x on the bottom-right corner. Instant replay functions only when camera and NVR times are synchronized.
/	Mute/unmute the sound of selected live channel. Audio Encode must be enabled (access from Main Menu > Camera > Encode); otherwise, the sound will keep silent and the unmuting has no effect.
	Digital zoom in/out on the selected live feed. <ul style="list-style-type: none"> Zoom in: Click , then drag to draw a rectangle around the area you want to magnify. Pan: Click and drag to move around the zoomed view. Reset: Left-click or right-click anywhere on the zoomed image to return to the normal view.
	Click to enable the two-way audio.

Item	Description
	Enable to sound the siren for about 30 seconds.
	Enable to turn on the spotlight for about 30 seconds.
	When privacy mode activated, it will shield the selected live stream while keeping the video recording uninterrupted. Click Open or the icon again to restore.

5.3.5 Control Menu

Centralized menu for accessing configurations on recorded videos, system settings, and also provides quick accesses of partial settings. Right-click anywhere on the live view to access the NVR control menu.



The menu varies by different NVR types.

Figure 5-29 Control Menu

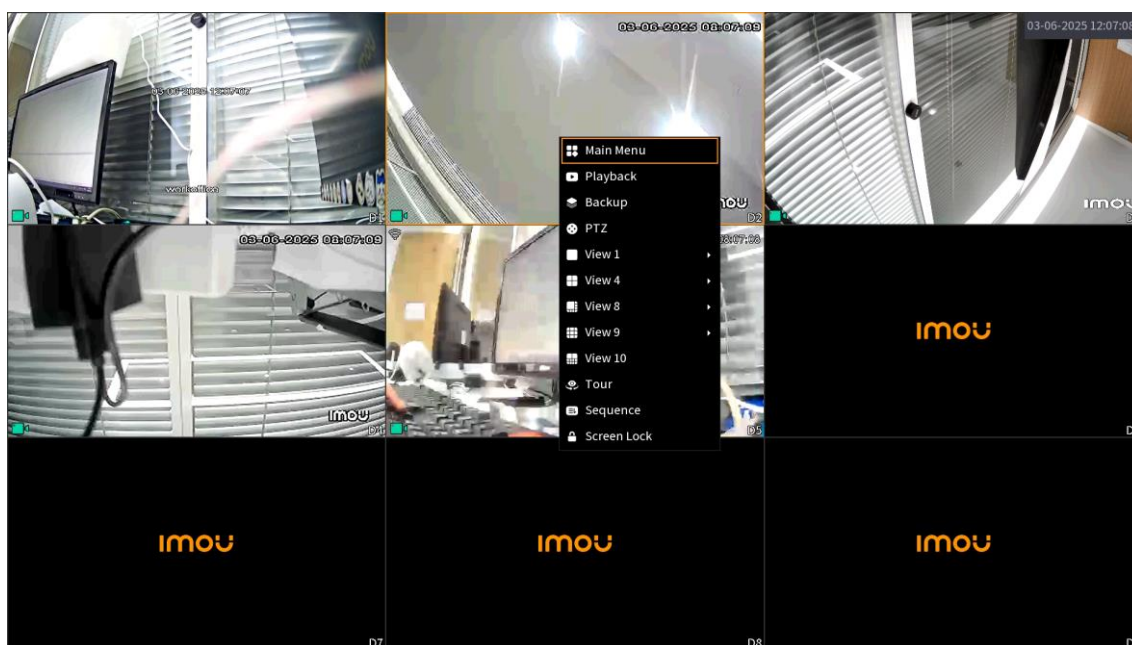

Table 5-12 Control Menu

Item	Description
Main Menu	Accesses settings including camera configurations, display, network, storage, backup, alarm and system management.
Playback	Review recorded footage with filtering capabilities by time, recording type, channel, etc. See "5.4 Playback" for details.
Backup	Export video footage to a USB storage device for safekeeping or future use. Refer to "5.5.1 File Backup."
PTZ	Operate PTZ cameras with pan/tilt movements, cruise patterns and more. See "5.3.6 PTZ" for details.
Multi-View Layout	Displays live feed of each channel in different layouts such as single view, 4 views, 8 views, etc.

Item	Description
Tour	Automatically switch between camera views with default or customized controls. See "5.6.2 Tour."
Sequence	Adjust the channel sequence on the live view. See the steps below: <ol style="list-style-type: none"> 1. Right-click on the live view and select Sequence. 2. Left-click and drag the channel to the desired position, then release the mouse button. 3. Click OK to confirm. The new sequence will apply to all layout modes.
Screen Lock	Click to immediately log out the account and you need to verify for next access.

5.3.6 PTZ

Control PTZ cameras directly from the live view interface such as adjusting zoom levels, move the camera lens, activate cruise mode, etc.



The settings may vary by camera models. Configuration options depend on camera's capabilities with some may not be configurable.



Step 1 On the live interface, right-click on a PTZ-enabled channel, then select **PTZ**.

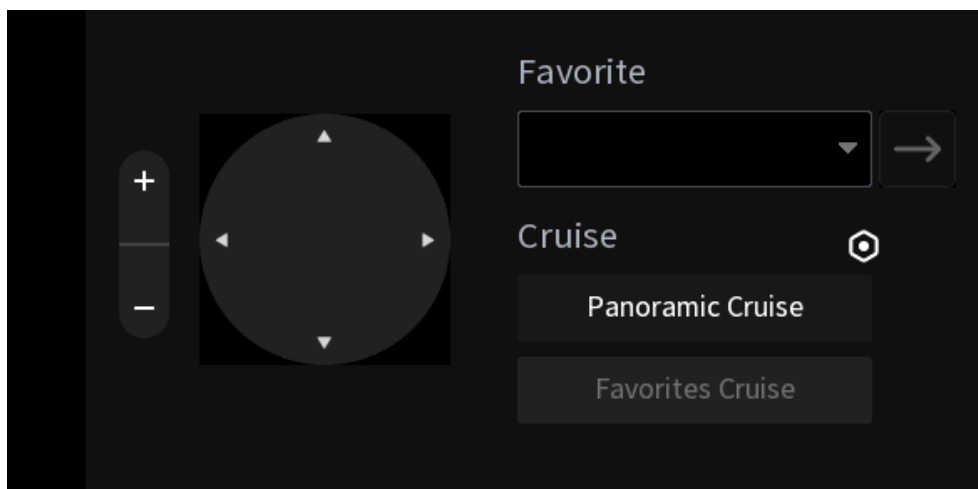



Figure 5-30 PTZ



Step 2 Configure the settings as needed, then right-click to exit.

Table 5-13 PTZ

Item	Description
	Zoom in/out. For zoom-capable cameras, click + to magnify the live view while click - to shrink.
	Pan/tilt. For pan-tilt cameras, click the arrow pad to adjust the lens horizontally or vertically.
Favorite	Select a preset position from the drop-down list, then click  . The camera will automatically turn to that site.

Item	Description
	 <p>Presets must be configured first. If not, click  to enter the settings. See "5.2.7 PTZ" for guidance.</p>
Cruise	<ul style="list-style-type: none"> ● Select a mode: Click the mode and it turns to orange. <ul style="list-style-type: none"> ◇ Panoramic Cruise: The camera automatically rotates by 360 degrees for complete area coverage, pausing at 6 evenly spaced points and dwell for a while at each. ◇ Favorites Cruise: The camera automatically tours through preset positions in sequence. ● Cancel the mode selection: Click the active mode again.  <ul style="list-style-type: none"> ● To activate the Favorites Cruise tour, ensure you have configured its settings in advance. ● To adjust the cruise settings, click . See "5.2.7 PTZ" for guidance.

5.4 Playback

Playback enables smart video review with various functions like timeline navigation, event filtering, clip export, multi-channel view, etc.



- The interface and functions may vary by different NVR types.
- The duration of available video playback depends on the HDD capacity. Oldest recordings will be overwritten once storage is full. To prevent data loss, please ensure important footage is backed up in advance.

Use either ways to access the playback:

- If you are on the live view interface, right-click, then select **Playback**.
- If you have entered the **Main Menu**, click  at the top-right corner.

5.4.1 Interface Overview

Here you can view recorded videos which can be filtered by time, recording type, channel, and even mark or clip videos for future reference.

Figure 5-31 Playback Display

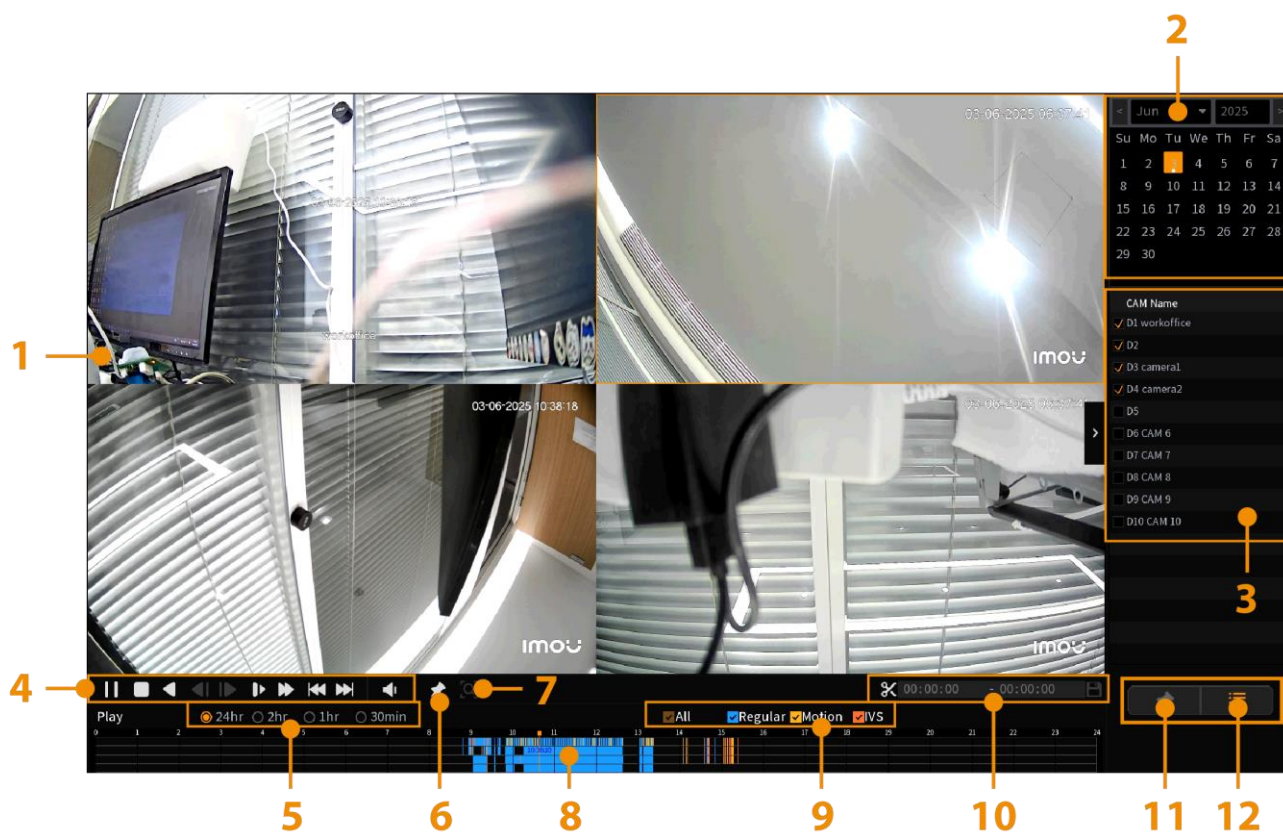











Table 5-14 Playback Display

No.	Item	Description
1	Recorded Video	Displays specified video recordings in the default 4-view layout. Click to expand to full screen.
2	Calendar	Dates with recordings are marked with a dot. Click to stop playback. Select a date to view videos and the timeline updates to show available video types.
3	Channel List	Click to stop playback. Select the channels you want to play back. Up to 4 channels can be played at the same time.
4	Playback Toolbar	Playback control bar. See "5.4.3 Playback Toolbar" for details.
5	Timeline Scale	In the playing or pausing state, select from 24hr, 2hr, 1hr, or 30min to adjust the timeline view.
6	Video Mark	While playing or paused, click to add a mark for a certain time frame. See "5.4.4 Video Mark" for detailed operations.
7	Smart Search	Click to define a search area to find and play motion-like events within it. See "5.4.5 Smart Search" for details.
8	Timeline	Displays video segments by time and type.

No.	Item	Description
		<ul style="list-style-type: none"> ● Shows up to 4 parallel timelines by default, which can be changed by selecting different channels. ● Timeline colors: <ul style="list-style-type: none"> ◇ Blue : Continuous video recordings. ◇ Yellow : Motion event recordings. ◇ Orange : Other smart event recordings like human and vehicles. ● Click anywhere on the timeline to start playback from this time point. Auto-jumps to the nearest recording if a blank area is clicked. ● While playing or paused, scroll the mouse wheel to zoom in/out the timeline from 24 hours to 30 minutes views.
9	Recording Type	<p>Click  to stop playback. Select the check box to specify the recording type to search for.</p> <p></p> <ul style="list-style-type: none"> ● To have Motion or IVS video recordings, ensure the specific detection type like Motion, Human or Vehicle has been turned on. See "5.2.5 Detection" for detection rules. ● At least one recording type will remain selected even if you uncheck the All option. ● All: All recording types will be played if selected. ● Regular: Continuous video recordings (blue timeline blocks). ● Motion: Motion event recordings (yellow timeline blocks). ● IVS: Other smart event recordings like human/vehicle (orange timeline blocks).
10	Video Clip	<p>Click  to clip videos of the selected channel. See "5.4.6 Video Clip" for details.</p>
11	Mark List	<p>Click  to stop playback. Click  to enter the mark list where you can review and manage the saved video marks. Refer to "5.4.4 Video Mark."</p>
12	File List	<p>Click  to view, filter and manage all recorded video segments of a specific channel. See "5.4.7 File List" for details.</p>

5.4.2 Mouse Operations for Playback

This section explains how to control recorded footage using mouse actions, including zooming, panning, and switching views in different layout modes.

Digital Zoom:

- Zoom in/out: Scroll the mouse wheel over any channel, or draw a frame to amplified the desired area.
- Pan: Click and drag to move around the zoomed view.
- Reset: Right-click to restore to the original view.

View Switching

- Four-view to single view: Double click any quadrant to maximize it.
- Full screen:
 - ◇ Enter: Double-click an already-maximized single view.
 - ◇ Exit: Double-click again or right-click repeatedly until view resets.

5.4.3 Playback Toolbar











The toolbar provides instant control over your media – adjust speed or different playing modes with a single click.

Figure 5-32 Playback Toolbar



Table 5-15 Playback Toolbar

Item	Description
	Play/Pause: Toggle between playing and pausing the video.
	Stop: Stop playback and reset to the beginning.
	Reverse: <ul style="list-style-type: none"> • During normal playback, click to play backward. Click to pause. • Click to resume the normal state.
	Play by Frame: <ul style="list-style-type: none"> • While paused, click or to move backward or forward by frames. • Click to resume the normal state.
	Slow Mode:

Item	Description
	<ul style="list-style-type: none"> During normal playback, click to reduce and cycle the playing speed from $\frac{1}{2}x > \frac{1}{4}x > \frac{1}{8}x > \frac{1}{16}x > normal$. In the slow play mode, click  (fast mode) to accelerate speed by one level. Click  to resume the normal speed.
	<p>Fast Mode:</p> <ul style="list-style-type: none"> During normal playback, click to accelerate and cycle the playing speed from $2x > 4x > 8x > 16x > normal$. In the fast play mode, click  (slow mode) to reduce speed by one level. Click  to resume the normal speed.
	<p>Day Skip:</p> <ul style="list-style-type: none"> Click  to play the videos of the previous day. Click  to play the videos of the next day.
	<ul style="list-style-type: none"> Mute/Unmute: Click  to mute the video and click  to unmute. Volume Adjustment: Hover over the audio icon, then drag the slider to adjust the audio volume.

5.4.4 Video Mark

Efficiently tag, navigate, and manage key moments in recorded footage. Video marks allow quick playback from specific timestamps and selective backup of important clips.

Add Marks



Only one channel can be marked at a time. During multi-channel playback, only the channel you've selected (highlighted in orange border) can be marked.

Step 1 While playing or paused, click  to add a mark at the current timestamp for the selected channel.

Figure 5-33 Video Mark



Step 2 Enter a name for the mark and click **OK** to save.

Figure 5-34 Add Marks

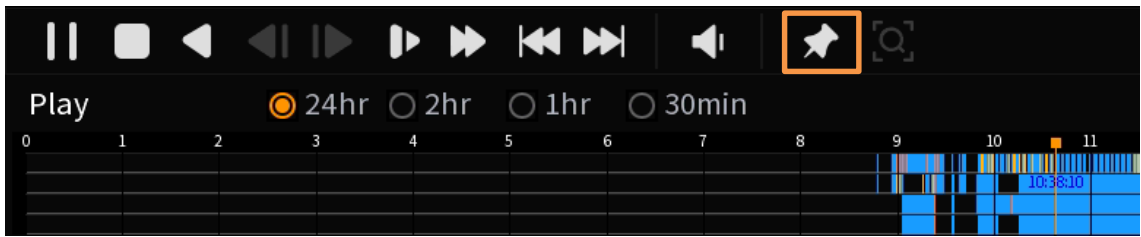
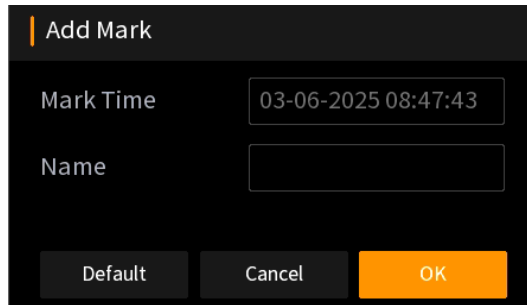

Use Marks



Only one channel's video marks can be viewed each time.

Step 1 Click  to stop playback. Select a channel of a specific date that you want to view its video marks.

Step 2 Click  to enter the mark list.

Figure 5-35 Enter Mark List



Step 3 (Optional) Enter the exact time on the upper box and click  to filter marks from this period.

Figure 5-36 Use Marks





Step 4 Double-click a mark in the list to start playback from the time frame defined by the mark.

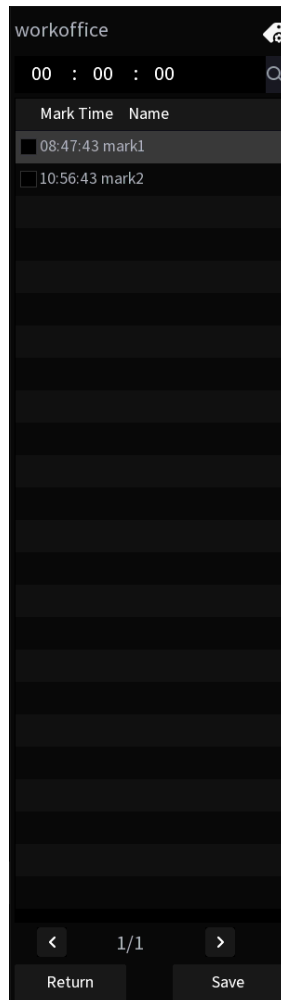

The "Return" function is disabled when watching a marked video. To exit from playing the video marks, and you need to stop the playing (not pause) the playing first.

Manage Marks

Step 1 Click  to stop playback. Select a channel of a specific date that you want to view its video marks.

Step 2 Click  at the bottom-right to enter the mark list, then click  at the upper-right corner

Step 3 Manage the mark information as needed.



All the mark information of the selected channel is listed chronologically.

Figure 5-37 Manage Marks

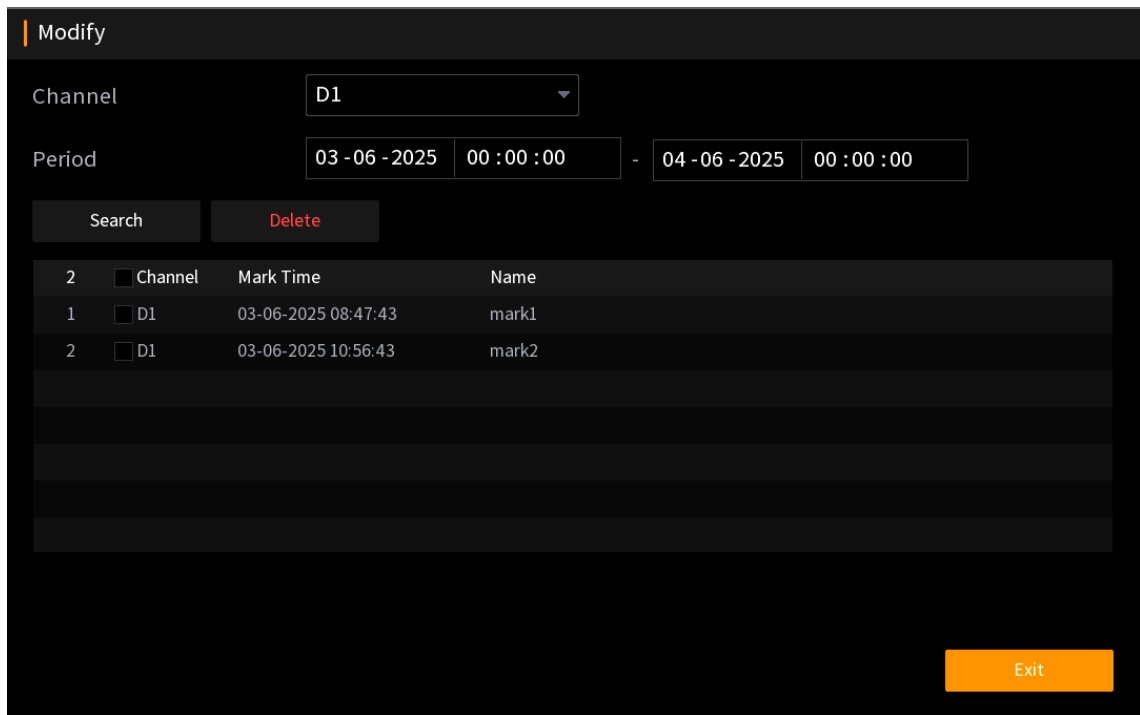



- **Search:** Select a channel, specify a time range, then click **Search** to retrieve its video marks.
- **Rename:** Double-click a mark in the list, then you can edit its name.
- **Delete:** Select a mark from the list, then click **Delete**.

Backup Marked Clips



Ensure you have insert a USB storage device with sufficient free space.

Step 1 Click  to stop playback. Select a channel of a specific date that you want to view its video marks.

Step 2 Click  at the bottom-right to enter the mark list and select one or multiple checkboxes of marks as needed.

Step 3 Click  or the **Save** button.

Step 4 Select the storage device to save videos, then click **Backup** to copy the entire video segment containing that marked time point to the USB storage device.



Click **Remove** to clear the selected files out of the backup list.

Figure 5-38 Backup Marked Clips

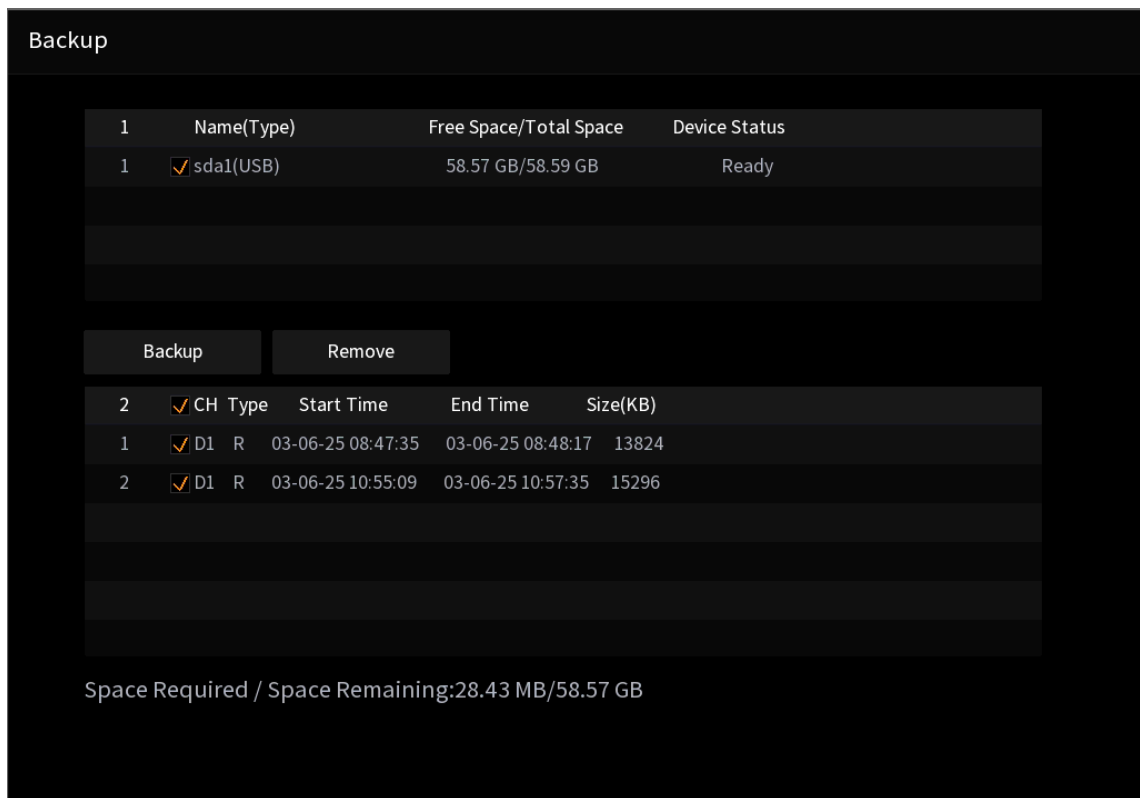

5.4.5 Smart Search

Set specific search area and the system will analyze and present recordings where motion events occurred in that zone.



Smart Search only operates on a single channel at a time. In multi-channel view, double-click a channel to switch it into a single view.

Step 1 Click  to stop playback. Select a channel of a specific date.

Step 2 Start the playback, then click . The whole video is overlaid with grids.

Figure 5-39 Start Smart Search

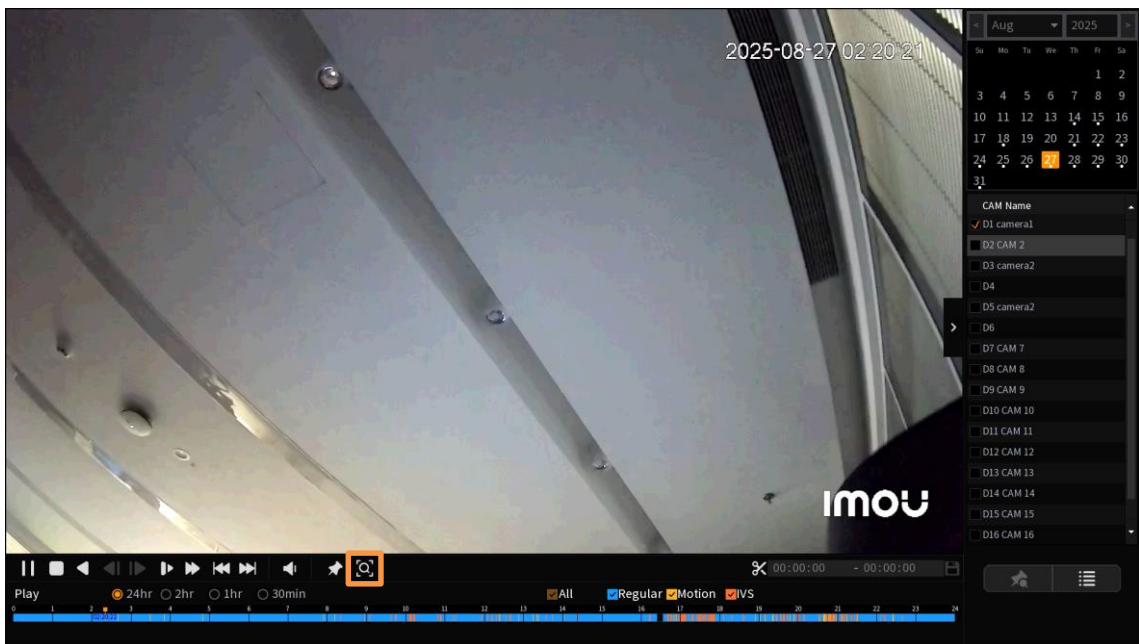



Step 3 Click and drag to set search areas which will be highlighted in orange.

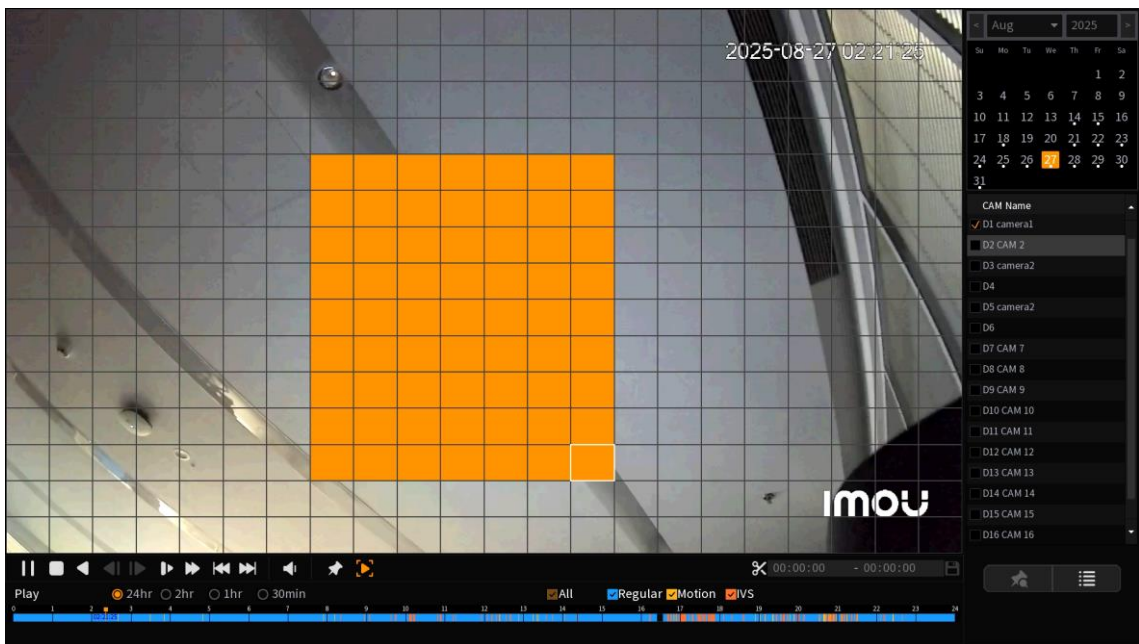

The region for search cannot be drawn in full screen mode.

Figure 5-40 Draw Search Area



Step 4 Click  to automatically play video segments that have event recordings (e.g., motion) occurred in that predefined area.



During smart playback, the timeline is inactive to navigate between different video segments.

To jump between events, you can access the **File List**  and double-click the listed event to play the recording.

Step 5 Left-click  or right-click anywhere on the video, then confirm the exit message to finish.

5.4.6 Video Clip

Save video segments by marking start/end times and exporting to a USB storage device.



- Only one channel's videos can be clipped each time. During multi-channel playback, clips are only captured from the channel you've selected that is highlighted in orange border.
- A USB storage device must be inserted before saving video clips.

Step 1 Click  to stop playback. Select a channel of a specific date, then start playback.

Step 2 Click  to set the clip's beginning time.

Figure 5-41 Video Clip



Step 3 Repeat the previous step to mark the end time.

Step 4 Click  to save the clips to the USB storage device.

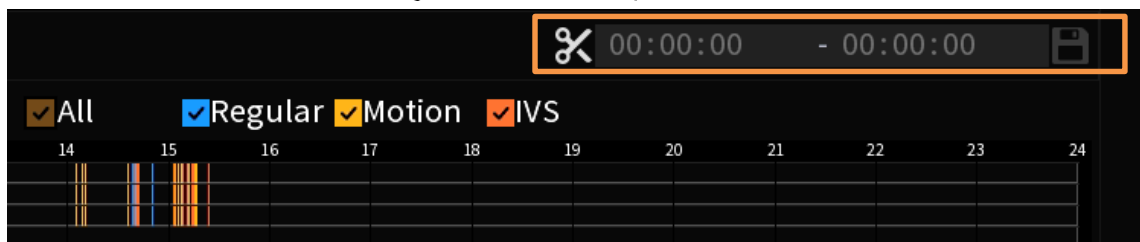
5.4.7 File List

View, filter and manage all recorded video segments by channel, date, and event type.

Step 1 Click  at the lower-right to enter the file list for one or multiple selected channels on a specific date.

Figure 5-42 Enter File List



Step 2 (Optional) Enter the exact time on the upper time box and click  to display files from that period.

Figure 5-43 File List



Step 3 Double-click a file to play.

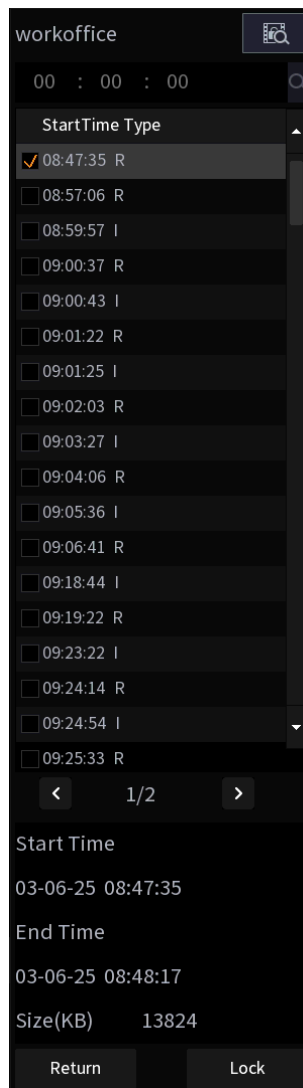

- File types: File types can be found in the list with different letters.
 - ◇ **R (Regular)**: Continuous video recordings (blue timeline blocks).
 - ◇ **M (Motion)**: Motion event recordings (yellow timeline blocks).
 - ◇ **I (IVS)**: Other smart event recordings like human and vehicles (orange timeline blocks).
- During multi-view playback, all selected channels will play their own video segments simultaneously, but the file list only displays footage from the selected channel identified with the smallest "D+digit" mark in the channel list below the calendar. To view other channel's video files, click on its video window while it is active.

Backup Files



Ensure you have insert a USB storage device with sufficient free space.

Step 1 Click  at the lower-right to enter the file list for one or multiple selected channels on a specific date.

Step 2 Select one or multiple files, then click .

Step 3 Click **Backup** to copy the selected files to the USB storage device.

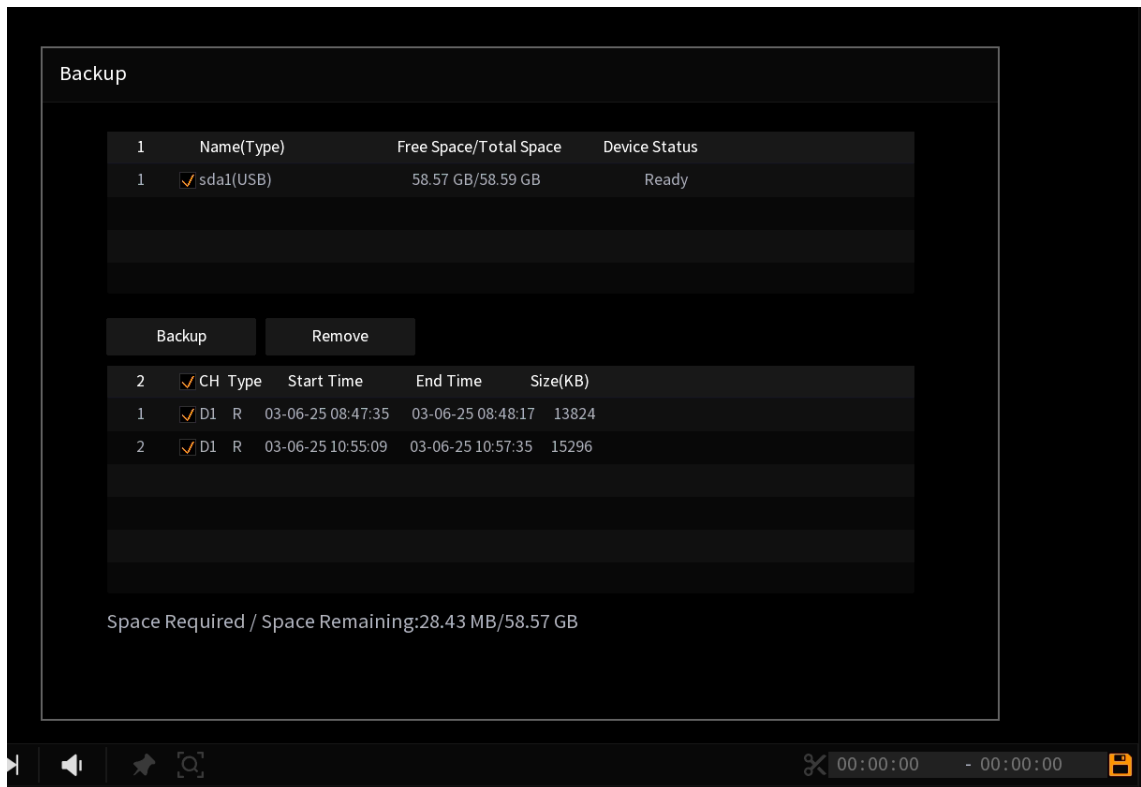

Click **Remove** to clear the selected files out of the backup list.

Figure 5-44 Backup Files



Lock/Unlock Files

Once the files are locked, they will not be overwritten when the HDD is full.

Step 1 Click  at the lower-right to enter the file list for one or multiple selected channels on a specific date.

Step 2 Lock or unlock event files.

- **Lock:** Select one or multiple files, then click **Lock** at the bottom-right corner. The locked file will be marked a  symbol.

Figure 5-45 Lock Files

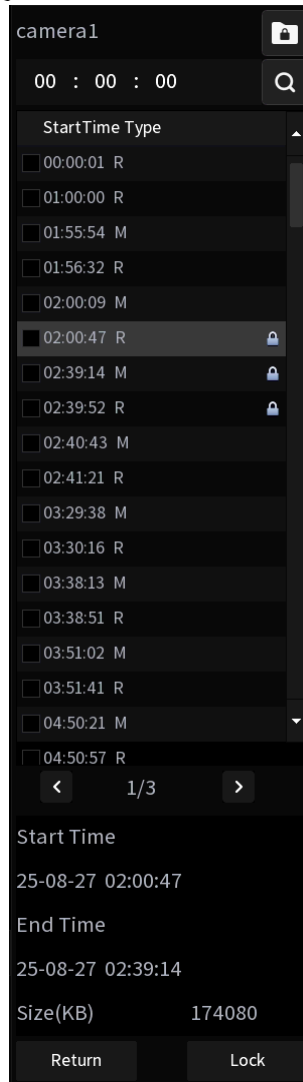

- Unlock:** Click  at the upper-right corner. Select one or multiple locked files, then click **Unlock**.

Figure 5-46 Unlock Files



5.5 Backup

You can backup important files to an external storage for future use or check them elsewhere.

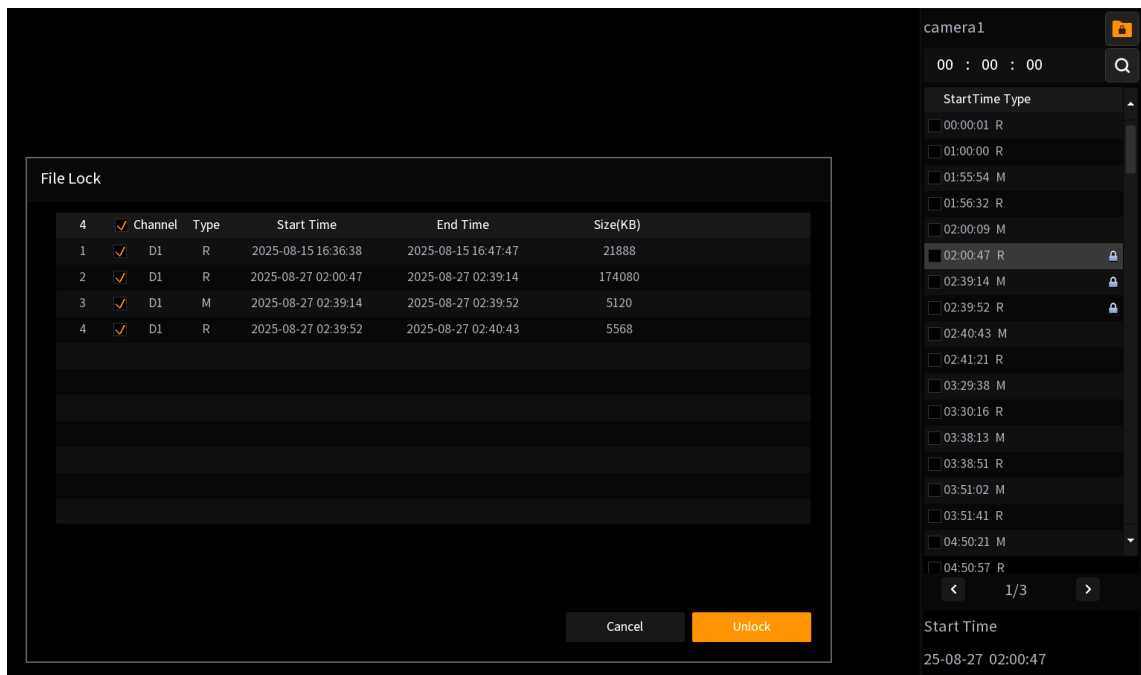
Insert a USB storage device, then on the pop-up interface, click an option to enter the process. For backup guides on files, logs and configurations, refer to the following sections. For system upgrade, see "5.10.4.2 System Upgrade"

Figure 5-47 Backup

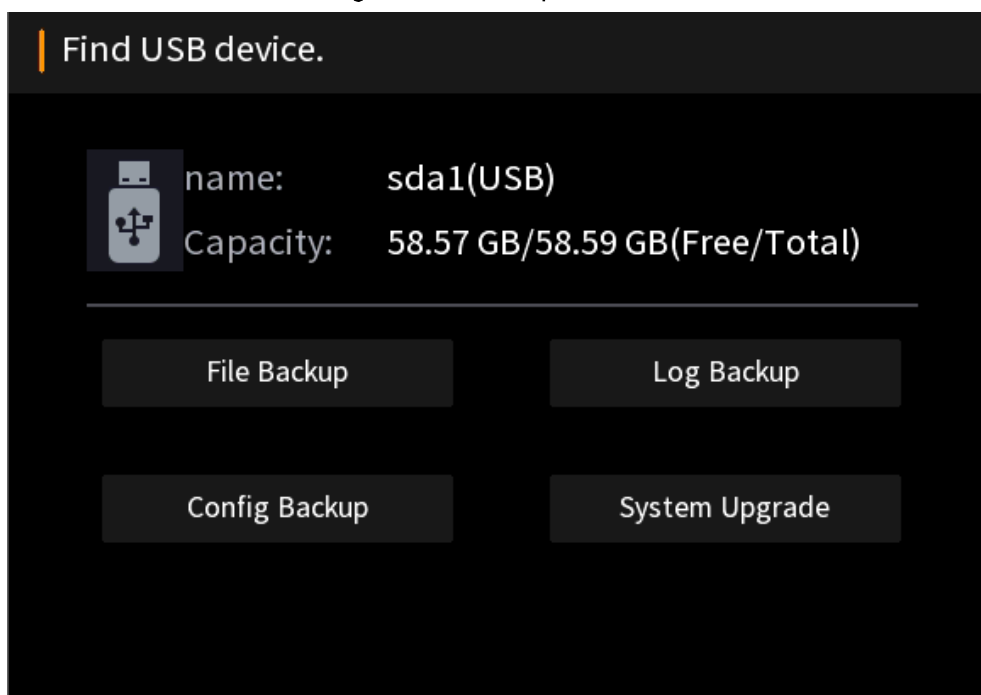

5.5.1 File Backup

Back up video recordings from the NVR to a USB storage device for offline storage or future use.

Step 1 Insert a USB storage, then select **File Backup**.



File Backup can also be accessed by:

- Method 1: Right-click on the live view, then select **Backup**.
- Method 2: Right-click anywhere on the live view and navigate to **Main Menu > Storage > Backup**.

Figure 5-48 File Backup

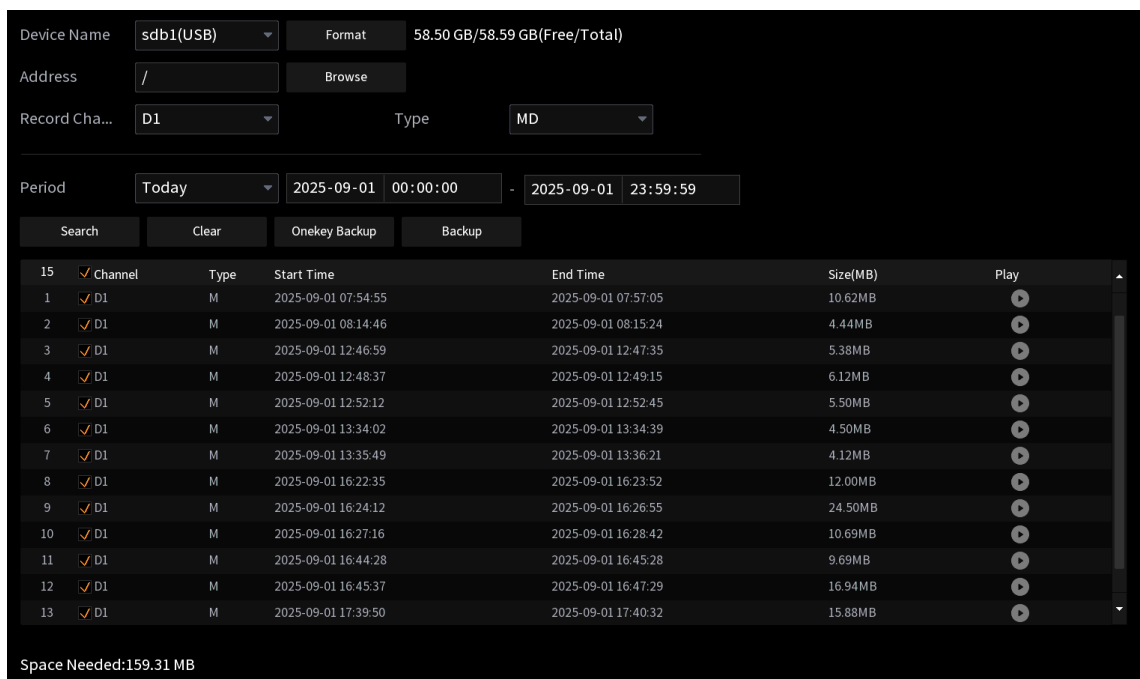

Step 2 Choose the channel and video type of the recording.

Step 3 Select the time range, set the start and end time, then click **Search**.



Click **Clear** to wipe all search results.

Step 4 Click **Browse** to select a folder on the USB device, then click **OK**.

Step 5 Select the videos to export, then click **Backup**. Wait for the system to upload.



- During backup, click **Stop** to cancel the process.
- When the backup is in progress, right-clicking to exit will not interrupt the process.
- Click **One-Key Backup** to export all found files at once.
- Click to watch the video file.

Step 6 Click **OK** to confirm the files copied to the USB storage and exit.



The backup files are mainly named "NVR_channel No._stream type_start time_end time.mp4."

5.5.2 Log Backup

Back up the system logs to the USB storage device for record-keeping or troubleshooting purposes.

Step 1 Insert a USB storage, then select **Log Backup**.

Figure 5-49 Log Backup

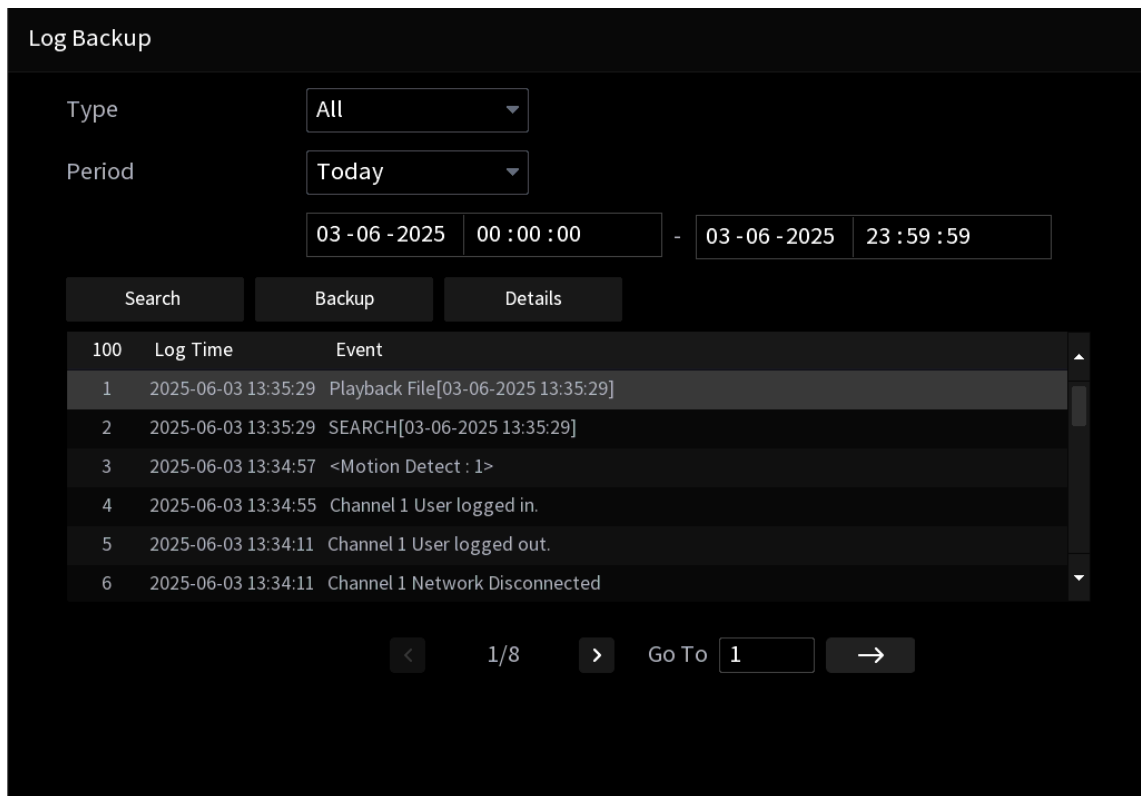

Step 2 Select the log type, time range, the start/end time, then click **Search**. Matching logs will appear in the list.



Click **Details** or double-click a log to view its contents.

Step 3 Click **Backup**. Select the path on the USB device, then click **OK** to export all searched logs.

5.5.3 Config Backup

Export NVR configuration files to a USB storage device. In case of abnormalities, just import the configuration files to recover the system.

Step 1 Insert a USB storage, then select **Config Backup**.

Figure 5-50 Config Backup

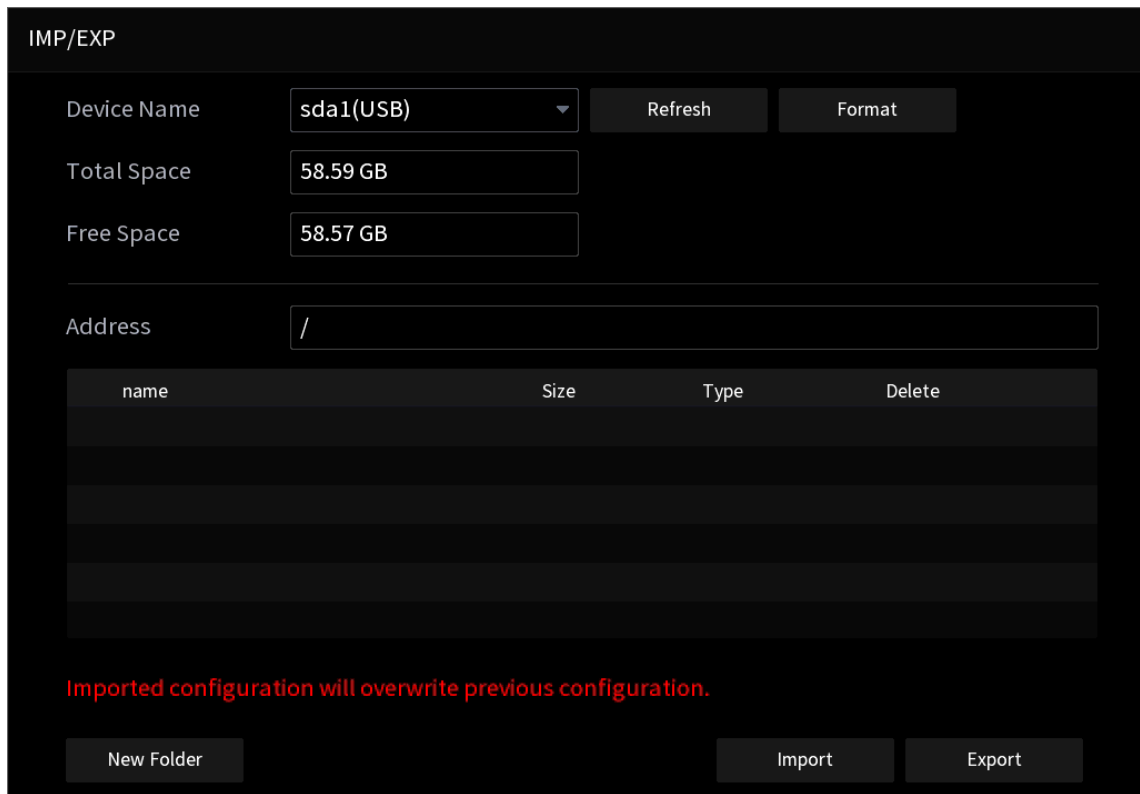

Step 2 Click **Import** or **Export** based on your needs.

- **Export:** Click **Export** and a file folder named "Config_time" will be automatically generated where exported configuration files will be stored.
- **Import:** Select the configuration folder containing the backup files, then click **Import**. All changes will take effect after the system reboots once configurations are imported.

5.6 Display Settings

These sections provide display customization and management of automated live view cycling.

5.6.1 Display

Customize the display to adjust visual elements like timestamps, resolution, channel title, transparency, etc.

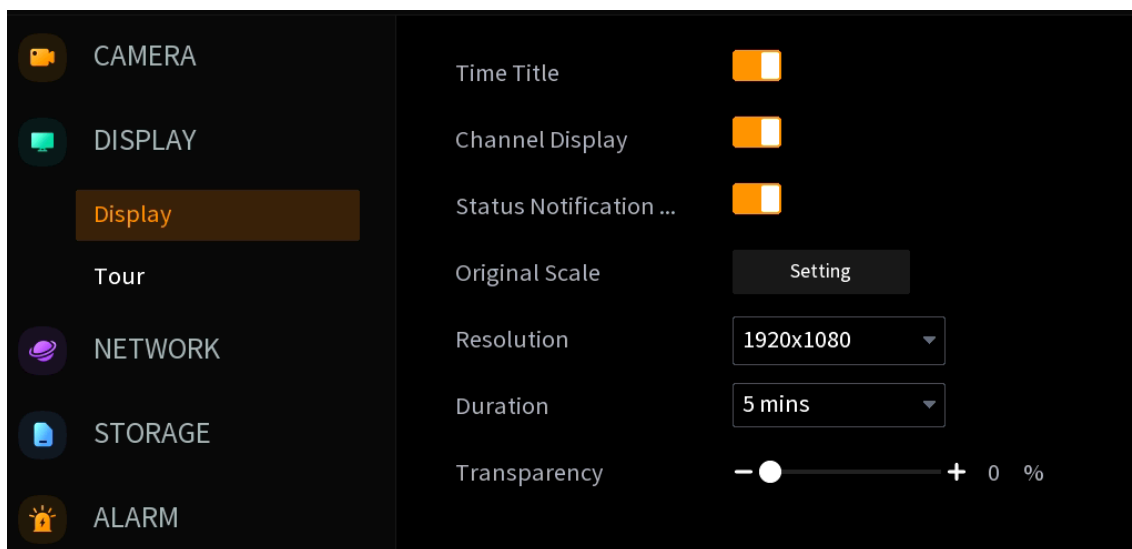

Step 1 Right-click anywhere on the live view and navigate to **Main Menu > Display > Display**.

Figure 5-51 Display



Step 2 Configure the settings as needed, then click **Apply**.

Table 5-16 Display

Item	Description
Time Title	Enable/disable the system's timestamp display in the top-right corner of the whole live view interface.
Channel Display	Toggle to show/hide channel IDs marked as D + digital at the bottom-right of each split view.
Status Notification Icon	Enable/disable the display of status icons (e.g., recording  , alarm ) in the bottom-left corner of each channel.
Original Scale	Reset the selected channel's video display to its original aspect ratio.
Resolution	Adjust the display resolution of the NVR's output signal to the connected monitor (max 4K via HDMI or max 1080p via VGA). If the selected resolution exceeds your monitor's capability, the monitor will temporarily go black and revert to the resolution it currently applied.
Duration	Select the duration of inactivity before the system automatically logs out and returns to the live view interface. You will need to re-authenticate for the next entry.
Transparency	Adjust the transparency of the setting menus. The higher the value, the more transparent it will be.
Default	Restore all Display settings to factory defaults.

5.6.2 Tour

Configure automatic cycling of camera live views with customizable display duration, layout patterns, and channel sequences for efficient monitoring.

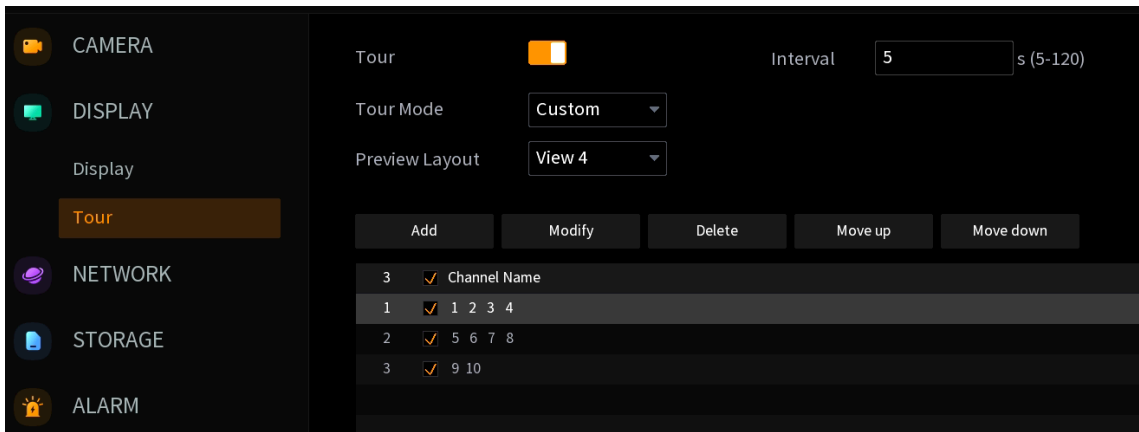

Step 1 Right-click anywhere on the live view and navigate to **Main Menu > Display > Tour**.

Figure 5-52 Tour





Step 2 Adjust the settings as needed.

Table 5-17 Tour

Item	Description
Tour	Enable/disable automatic view cycling.
Interval	Display duration for each channel group (default: 5 seconds).
Tour Mode	<p>Select the tour mode.</p> <ul style="list-style-type: none"> Default: Keep cycling through camera views according to the current live view layout (e.g., quad-view will always cycle 4 screens simultaneously).  In the default mode, each group on cycle should have at least one connected channel. Customized: Cycles views based on the defined layouts in Preview Layout.
Preview Layout	Select the layout pattern to be cycled. For example, if you select View 1, it will cycle through selected channels individually and display them in full-screen sequentially.
Channel Group for Cycle	<p>Displays all configured channel groups that will be cycled according to your selected Preview Layout mode.</p> <ul style="list-style-type: none"> Add: Create new channel groups that match the layout's capacity. For example, for 9-view layout, select 9 channels per group. Modify: Double-click a channel group or select it and click Modify, then you can reselect the channels to be cycled for this group. Delete: Click to remove the selected channel group. Move UP: Click to advance the selected channel group in cycle sequence. Move Down: Click to delay the selected channel group in cycle sequence. <p> In customized mode, the system initially selects all channels across every layout mode, including empty/unassigned channels. If you want to only cycle your desired layout, deselect all checkboxes of channels from the other layout modes; otherwise, these layouts will also appear in cycling if their channels remain checked.</p>

Item	Description
Default	Click Default to restore the tour settings to factory defaults.

Step 3 Click **Apply** to start automatic live feed cycling. There will be  on the upper right of the live interface, representing the Tour has been activated. Click it again to pause the tour and the icon switches to .

5.7 Network Settings

This section controls the NVR's network connectivity, including IP assignment, customizable ports and cloud services for remote access via Imou Life app.

5.7.1 Network Configuration

Make network configurations of the NVR such as IP, MAC, DNS settings, etc.



Make sure the NVR has connected to the network properly.

Step 1 Right-click on the live interface and navigate to **Main Menu > Network > Network Config**.

Figure 5-53 Network Configuration

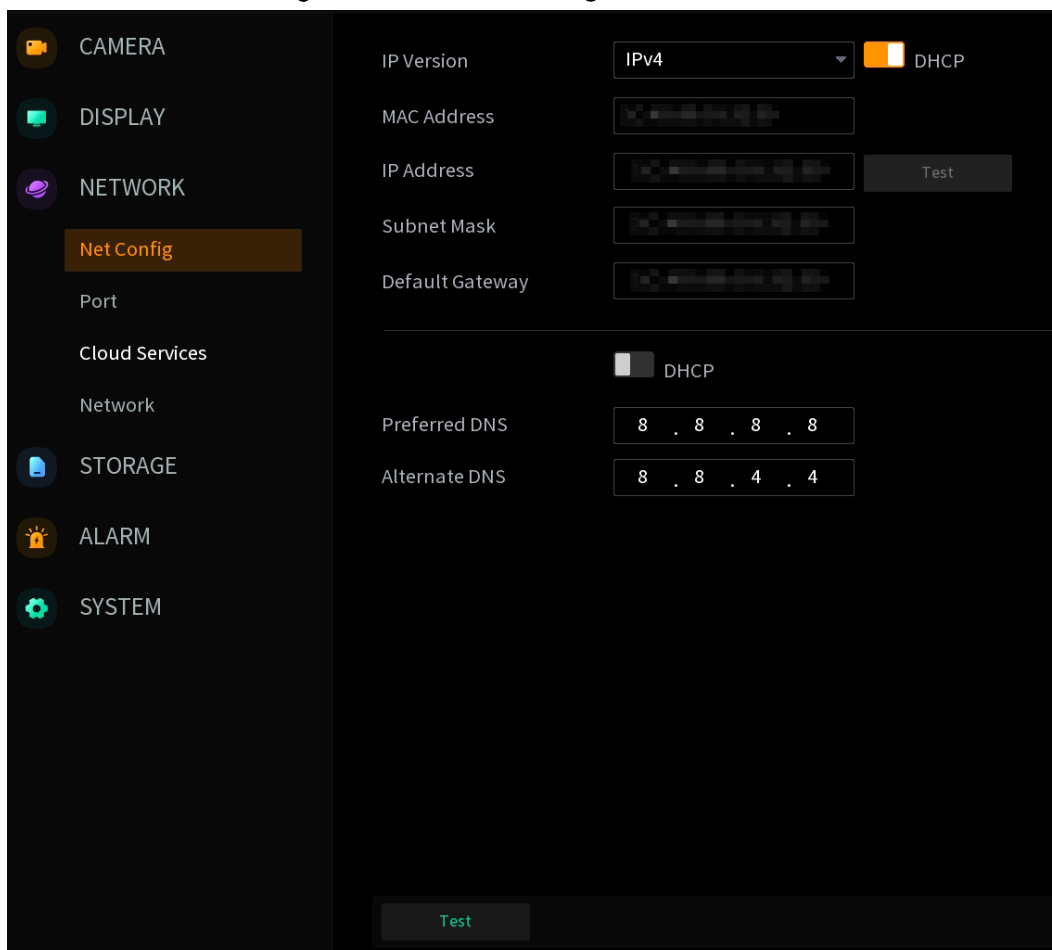

Step 2 Configure the parameters, then click **Apply**.

Table 5-18 Network Configuration

Item	Description
IP Version	Both IPv4 and IPv6 addresses are supported and switchable.
MAC Address	Displays the MAC address of the NVR.
DHCP	When DHCP is enabled and works correctly, it automatically assigns the IP address, subnet mask, and default gateway, making these fields non-configurable. To manually configure these parameters, disable DHCP first. Afterwards, click Test to check for IP addresses conflicts.
IP Address	
Subnet Mask	
Default Gateway	 IP address and default gateway must be in the same network segment.
DNS DHCP	When the above DHCP is enabled and functioning, turn on the DHCP for DNS will automatically assign the DNS IP addresses. To manually enter these IPs, disable the DHCP for DNS.
Preferred DNS	The IP address of the primary DNS server.
Alternate DNS	The IP address of the backup DNS server.
Test	Test for average delay, packet loss rate and network status.

5.7.2 Port

You can set the maximum number of simultaneous connections to the NVR (e.g., from mobile devices and laptops) and customize port settings as needed.

Step 1 Right-click on the live interface and navigate to **Main Menu > Network > Port**.

Figure 5-54 Port

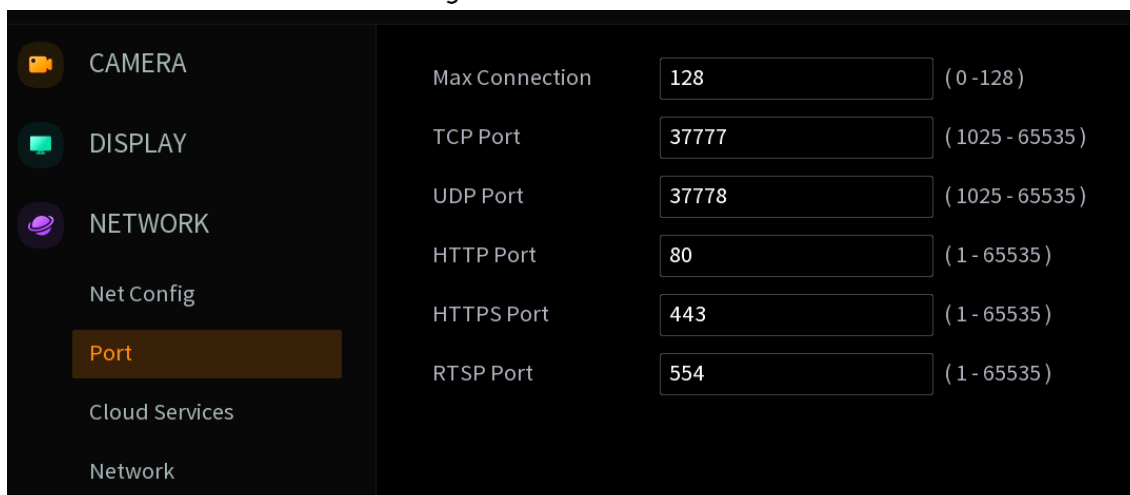

Step 2 Configure the parameters, then click **Apply**.



Except for the **Max Connection**, please reboot the NVR after you adjust any port parameters.

Table 5-19 Port

Item	Description
Max Connection	Set the maximum number of clients that can access the NVR simultaneously (e.g., mobile/PC Imou Life client or other allowed app). Range: 1–128. Default: 128.
TCP Port	Default: 37777 . Modify as needed.
UDP Port	Default: 37778 . Modify as needed.
HTTP Port	Default: 80 . Modify as needed.
HTTPS Port	Default: 443 . Modify as needed.
RTSP Port	Default: 554 . Modify as needed.

5.7.3 Cloud Services

Enabling the **Cloud Services** will allow you to add the NVR to the Imou Life app for remote live viewing and device management.



For this feature to work, ensure the NVR has an active Internet connection.

Step 1 Right-click on the live interface and navigate to **Main Menu > Network > Cloud Services**. (keep it open for later use). Ensure you have turned on **Cloud Services**; otherwise you may fail to add the NVR to the app.

Figure 5-55 Cloud Services

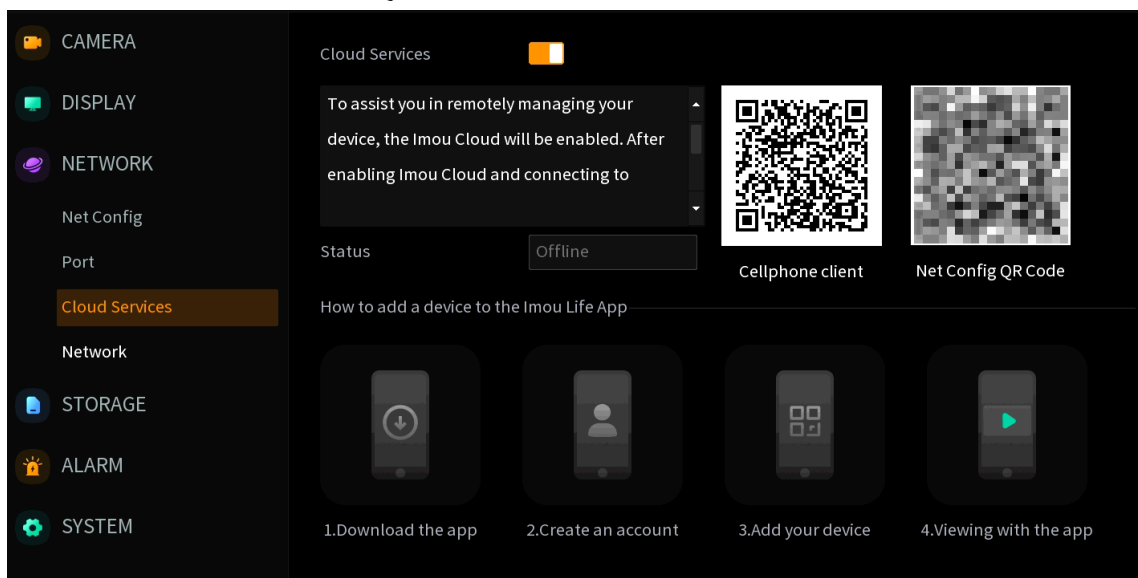

Step 2 Install the Imou Life app.



If you already have the app, ensure it is up-to-date.

- Option 1: On the **Cloud Services** interface, scan the left **Cellphone Client** QR code with your phone, then download the app.
- Option 2: Search for Imou Life in the app store to download the app.

Step 3 Add the NVR to the app.



The **Status** on this interface will change to **Online** once the NVR linked to the app.

- 1) Launch the app. Create an account and log in.
- 2) Tap **+** in the upper-right corner and scan **Net Config QR Code** (the right one) from NVR's **Cloud Services** interface. Alternatively, scan the QR code on the label located at the bottom of the NVR.

Figure 5-56 Scan Device QR Code

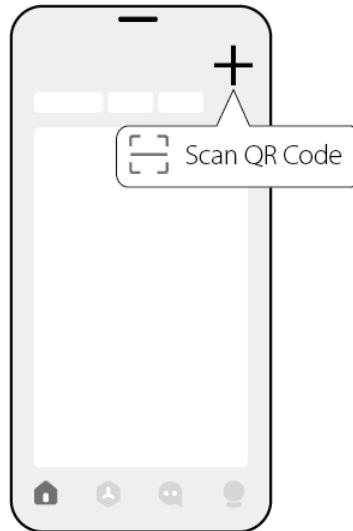

- 3) Live view and device management: Once added, access the NVR from app's homepage. Tap **Bind All**, and all cameras connected to the NVR will be available for live monitoring and setting adjustments via the app.

5.7.4 Network

You can view the general network performance and connectivity analysis with load monitoring, network testing and packet capture.

5.7.4.1 Load

You can check the real-time send/receive speeds of data for Ethernet connections. To access: Right-click on the live interface and navigate to **Main Menu > Network > Network > Load**.

Figure 5-57 Load



5.7.4.2 Test

It allows you to check the connection quality between the NVR and connected devices by measuring latency, packet loss, and overall network status. For deeper troubleshooting, the Packet Capture Backup tool records network traffic when abnormalities occur.

Network Test

You can verify the network connection status between the NVR and its added devices.

Step 1 Right-click on the live interface and navigate to **Main Menu > Network > Network > Test**.

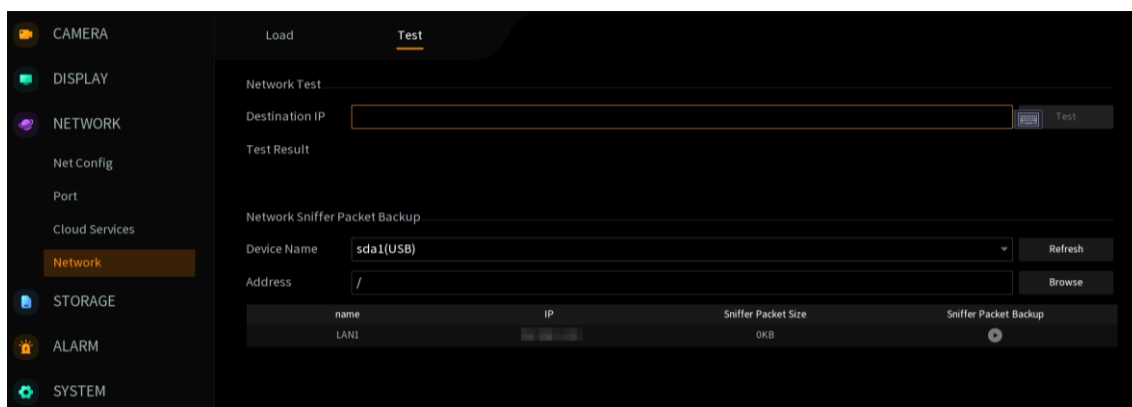

Figure 5-58 Test



Step 2 Enter the **Destination IP** of the device to be tested, then click **Test**. The system will show the test results including the average delay, packet loss rate and network status.

Network Sniffer Packet Backup

Packet capture records network traffic data for troubleshooting. If the NVR encounters network issues, you can save the captured packets (*.pacap file) to a USB device and provide it to the technical support for analysis.

- Step 1** Right-click on the live interface and navigate to **Main Menu > Network > Network > Test > Network Sniffer Packet Backup**.
- Step 2** Inset a USB storage device to the NVR and refresh the interface. The USB storage will appear under **Device Name**.
- Step 3** Click **Browse** and select a save path on the storage device. Ensure sufficient storage space is available.
- Step 4** Click  to start packet capture.
 - 
 - Only one capture process can run at a time.
 - You can navigate to other interfaces during capture without interrupting the process.
- Step 5** Wait for the process to complete or click  to stop the capture. The file will be saved as *.pacp on the storage device.

5.8 Storage

Set up 24/7 non-stop or event-triggered recordings, view HDD health and capacity, and export footage to USB for offline storage.

5.8.1 Schedule

The NVR records video based on your configured schedule, either continuously or only when events are detected.

- Step 1** Right-click on the live interface and navigate to **Main Menu > Storage > Schedule**.

Figure 5-59 Schedule







- Step 2** Select video recording mode from **Normal** or **Event Recordings**.

5.8.1.2 Normal Recordings (Default)

Non-stop video recordings even when no events occurred – blue timeline blocks in playback. You can set recording periods by drawing or editing. By default, the entire week is set to 24/7 recording.

Draw Mode (Visual Timeline Editing)

Step 1 Edit recording periods.

- **Create detection periods:** Left-click or drag on the timeline to create up to five detection periods (shown as orange block), each divided into 30-minute interval.
- **Remove detection periods:** Click or drag the existing period to remove or edit this period.
- **Synchronous actions:**
 - ◇ Click  next to **All** – symbols of all days will change to . Adjust settings for one day and changes will apply to all days automatically.
 - ◇ Click  next to individual days – their symbols will change to . Adjust settings for selected days and changes will sync only to the marked days.
- **Restore defaults:** Click **Default** to reset to non-stop 24/7 detection.

Step 2 Click **Apply** to save settings.

Edit Mode (Precise Time Entry)

Step 1 Click  next to any date.

Figure 5-60 Precise Period Entry

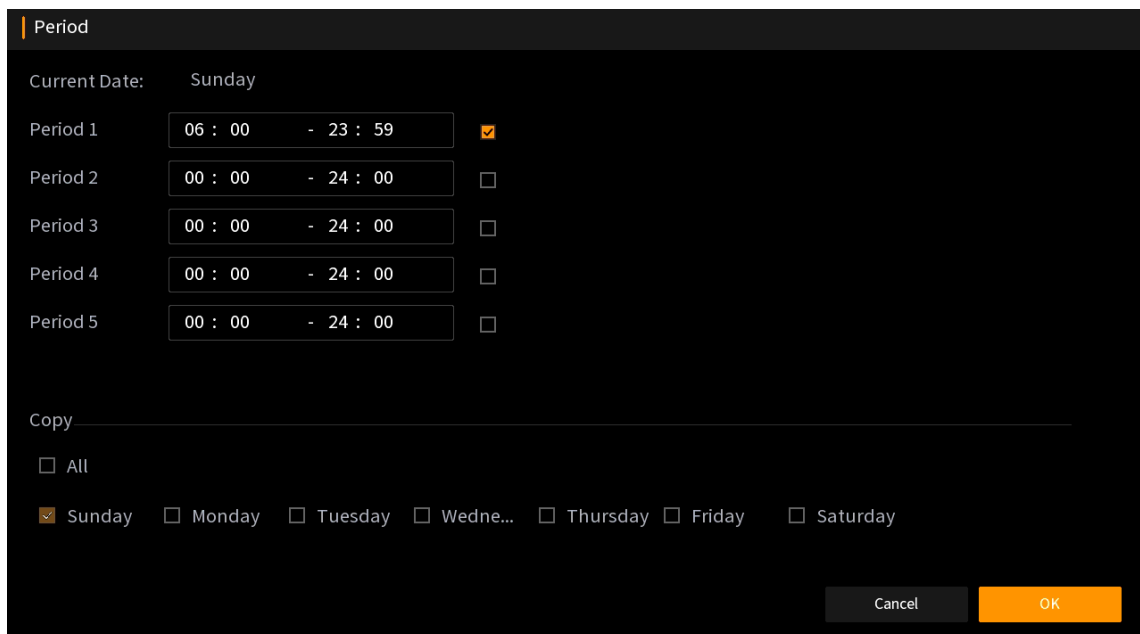

Step 2 Enter up to five exact time periods, then check the box to make it take effect.



The period already defined in the drawing mode will be marked a tick beside the time entry box. Uncheck the box will remove the preset time period.

Step 3 (Optional) Click **Copy** to duplicate the current settings to the entire week (select **All**) or partial dates (select specific dates).

Step 4 Click **OK**.

Step 5 Click **Apply** to finish period settings.

5.8.1.3 Event Recordings

Event-triggered recordings – recordings only take place when an event is captured; show in colored timeline blocks in the playback.



Event recordings will not occur unless you have set detection rules (e.g., types, zones, and schedules) as detailed in "5.2.5 Detection."

Figure 5-61 Event Recordings

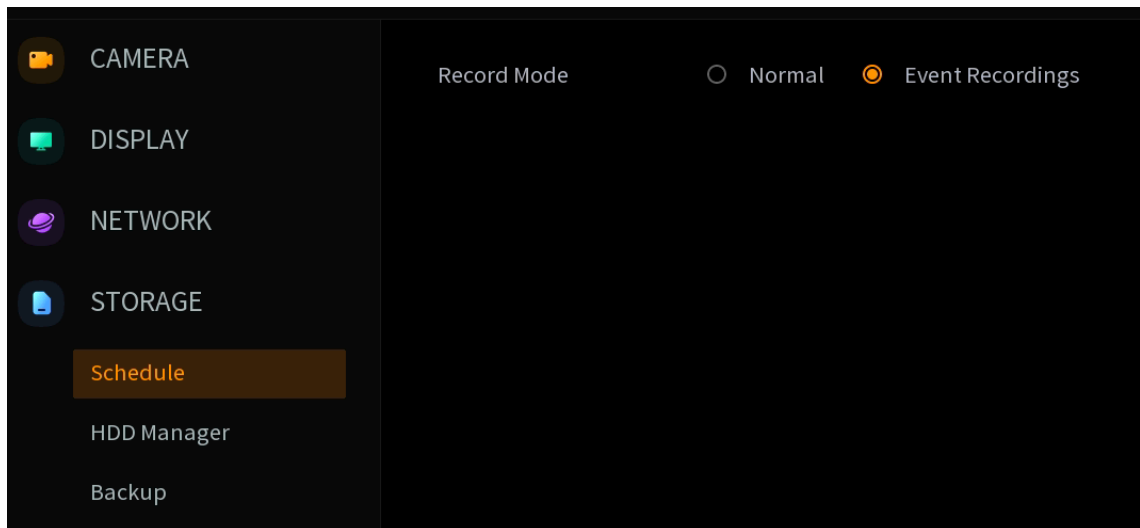

5.8.2 HDD Manager

Here you can get the information of the installed hard drive, including:

- Total and available storage capacity
- Drive health status
- Drive identification name
- The read/write status of the drive

Access HDD Manager

Right-click on the live interface and navigate to **Main Menu > Storage > HDD Manager**.

Format a HDD

Step 1 Select the desired HDD from the list.

Step 2 Click **Format** at the bottom-left corner and confirm the prompt message.

Figure 5-62 HDD Manager

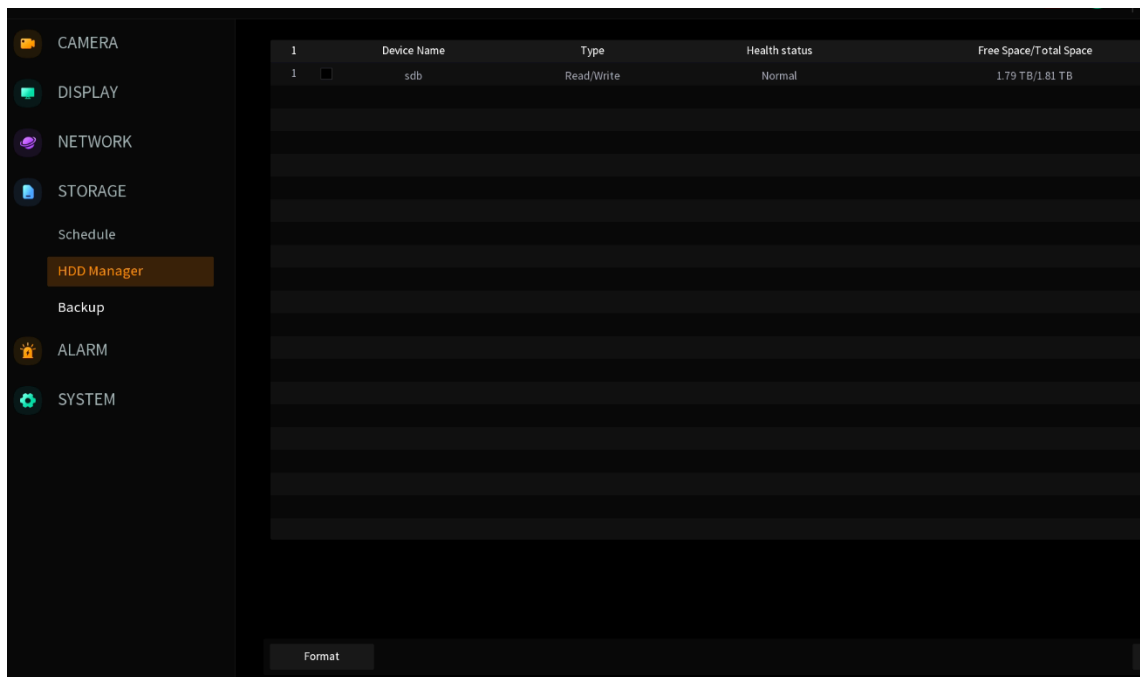

5.8.3 Backup

Export video recordings from the NVR to USB storage for archiving or backup purposes. See "5.5.1 File Backup" for details.

5.9 Alarm

It provides alarm logs for history and real-time alerts like pop-up messages or sounds to system abnormalities or specific events.

5.9.1 Alarm Info

View and manage alarm logs, including event details, video playback, and log exports.

Step 1 Right-click on the live interface and navigate to **Main Menu > Alarm > Alarm Info**.

Figure 5-63 Alarm Info

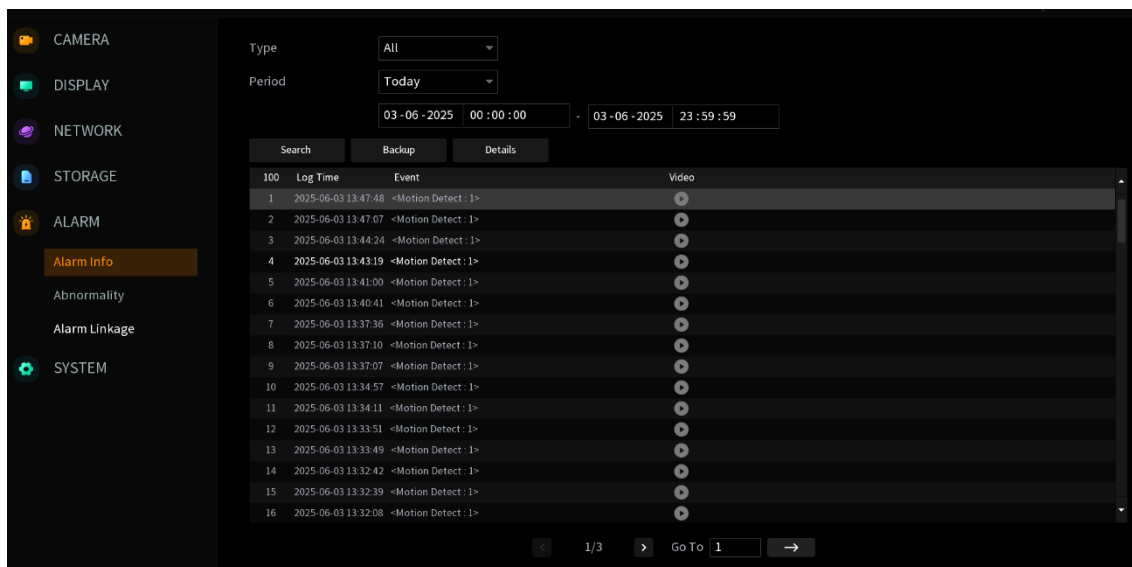

Step 2 Select the alarm type.

Step 3 Specify the time range, set the start/end time, then click **Search**. Matching alarm information will be listed where you can see the event happening time, event types and more.

- Click  to view event videos that are available for some types of the events.
- Click **Backup** to export the log of the selected event to a USB storage device.
- Double click an alarm message or click **Details** of the selected message to view the detailed information of the selected event (e.g., type, channel, time or videos if available).

5.9.2 Abnormality

Configure system alerts for abnormality events like hardware failures, network issues, and camera disconnections.

Step 1 Right-click on the live interface and navigate to **Main Menu > Alarm > Abnormality**.

Figure 5-64 Abnormality Alarm

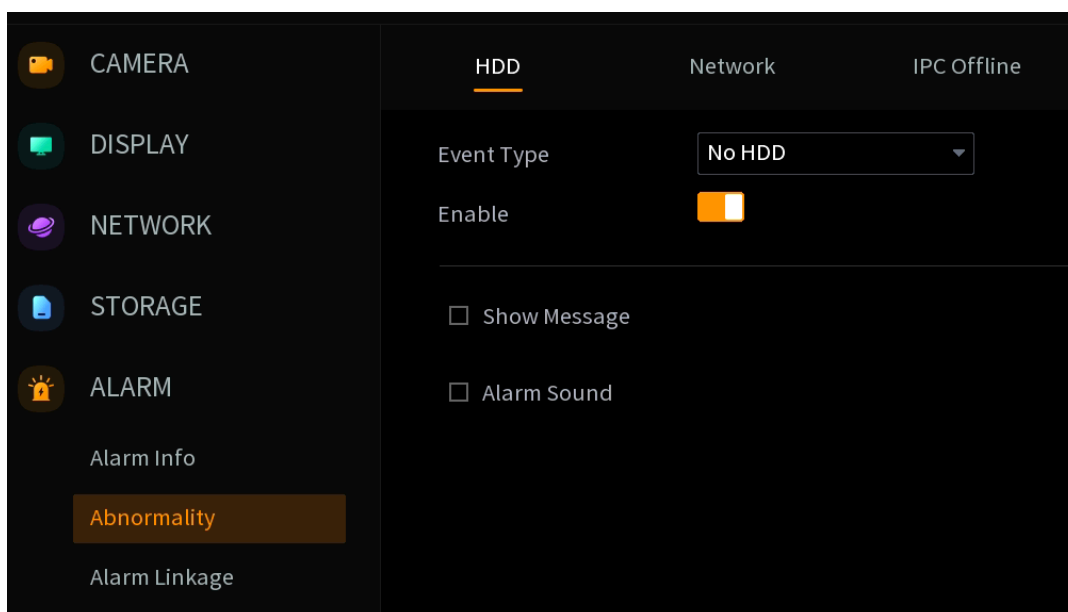

Step 2 Configure the settings, then click **Apply**.

Table 5-20 Abnormality Alarm

Item	Description
Abnormality Type	Click different tabs to access: <ul style="list-style-type: none"> ● HDD: Select from No HDD, HDD Error. ● Network: Select from Network Disconnection, IP Conflict, MAC Conflict. ● IPC Offline: Select from different channels.  Available abnormality types may vary and the actual interface shall prevail.
Enable	Toggle it on to activate alarms when the selected abnormality occurs.
Show Message	Check the box to display pop-up alerts on the live interface when the selected abnormality occurs.
Alarm Sound	Check the box to give out audible beeps when the selected abnormality occurs.

5.9.3 Alarm Linkage

Configure automated responses (visual/audio alerts) for detected events like motion or people.

Step 1 Right-click on the live interface and navigate to **Main Menu > Alarm > Alarm Linkage**.

Figure 5-65 Alarm Linkage

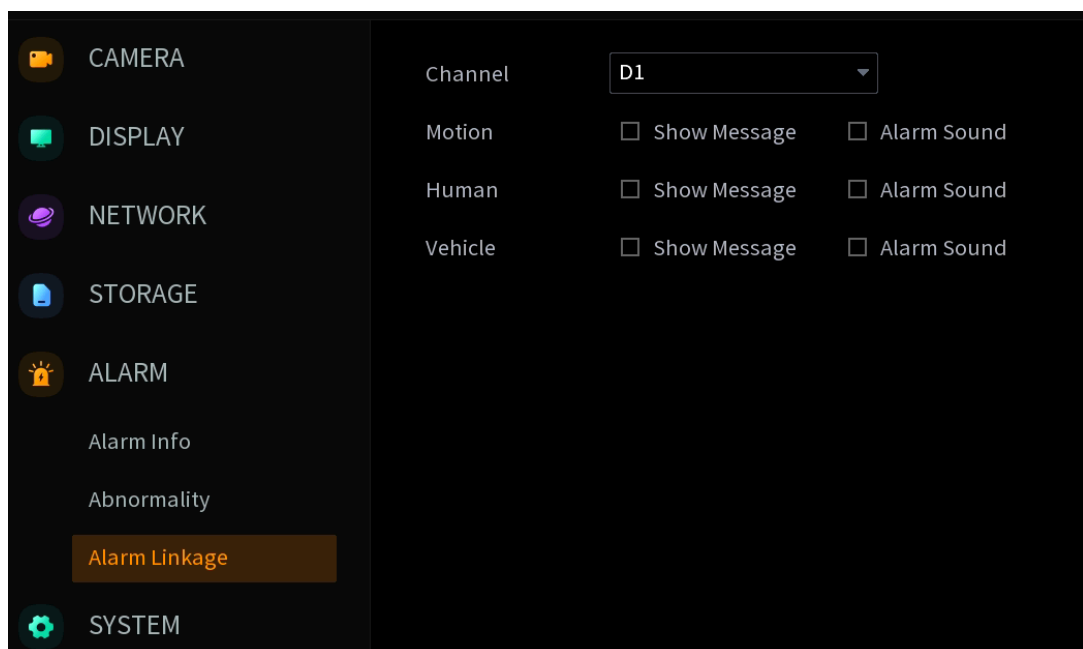

Step 2 Configure the settings, then click **Apply**.

Table 5-21 Alarm Linkage

Item	Description
Channel	Select a channel to configure.

Item	Description
Show Message	Check the box to display pop-up alerts on the live interface when the corresponding event occurs.
Alarm Sound	Check the box to give out audible beeps when the corresponding event occurs.
Alert Type	Triggers predefined alarms (on-screen alert/alarm sound) upon detecting specific events (motion/human/vehicle).  Requires prior setup of detection rules (e.g., detection types, zones, and schedules) as detailed in "5.2.5 Detection."
Default	Restore the settings of current channel to factory defaults.
Copy	Replicate the current alarm settings to other selected channels.

5.10 System Settings

Critical system control and management over account, time, maintenance, log and more.

5.10.1 Basic Configuration

This section covers essential NVR settings, including device naming, language, video standard selection, instant replay, and time synchronization with connected cameras.

Step 1 Right-click on the live interface and navigate to **Main Menu > System > Basic Information**.

Figure 5-66 Basic Information

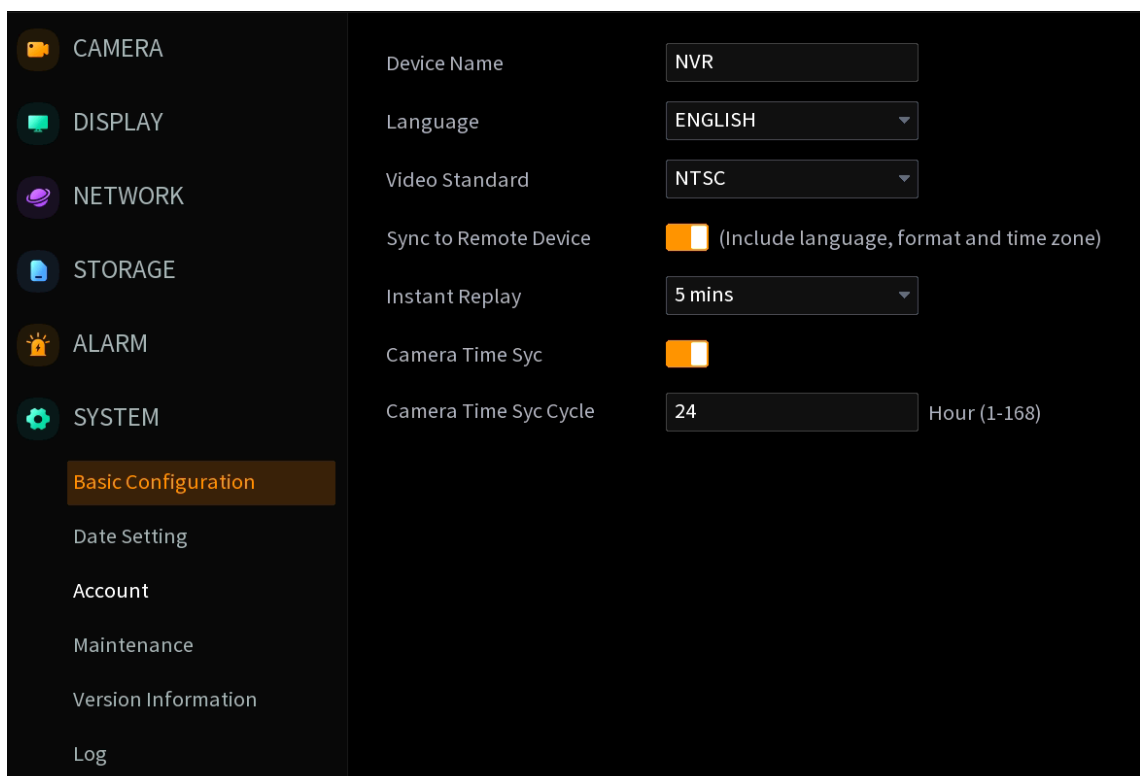

Step 2 Configure settings, then click **Apply**.

Table 5-22 Basic Information

Item	Description
Device Name	Customizable name for the NVR.
Language	Select the system language of the NVR.
Video Standard	Select from PAL and NTSC based on regional compatibility.
Sync to Remote Device	Synchronizes part of NVR settings to the connected cameras like language, video standard and time zone.
Instant Replay	Play back recent video footage (selectable from the last 5 to 60 minutes) of the specified channel. On the live view, click  on the toolbar to check.
Camera Time Sync	When enabled, NVR's system time will sync to the camera's. Disabling may affect the Instant Replay.
Camera Time Sync Cycle	Intervals for automatic time synchronization between the connected cameras and the NVR (e.g., every 24 hours).

5.10.2 Date

Includes time-related configurations such as system time, time zone, time format, DST, etc.



When the NVR has connected to the Cloud server, i.e., the Cloud Service is enabled and its status is Online (see "5.7.3 Cloud Services" for details), this date-related settings are not configurable as they will be automatically synchronized.

Step 1 Right-click on the live interface and navigate to **Main Menu > System > Date Setting**.

Figure 5-67 Date

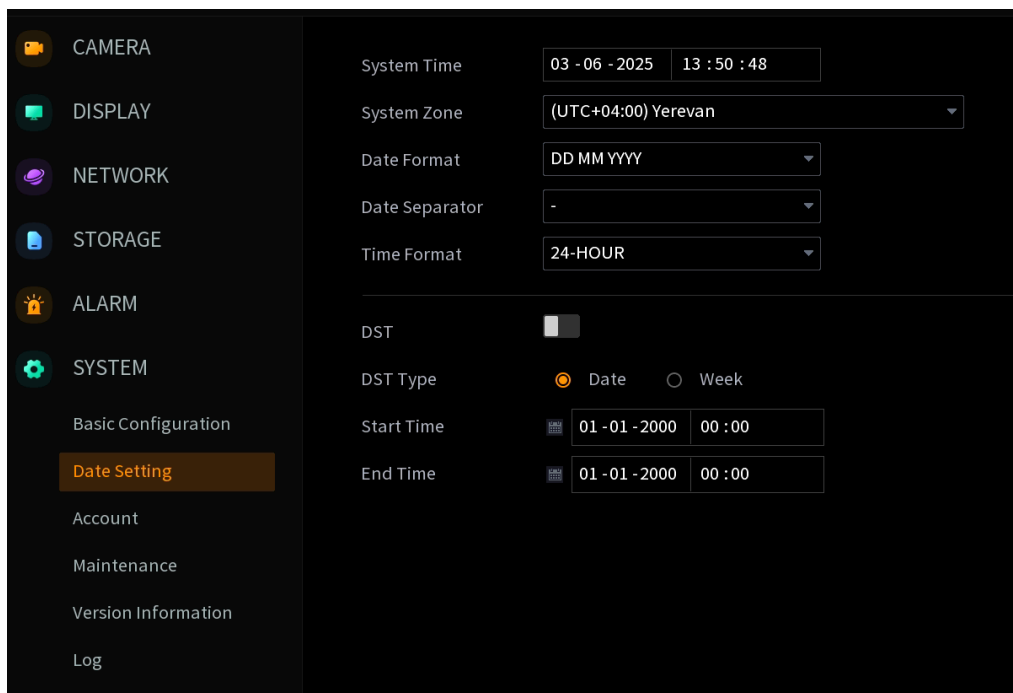

Step 2 Configure the settings, then click **Apply**.

Table 5-23 Date

Item	Description
System Time	Manually set the current date and time of the system.  Be cautious that the adjustment of the system time may affect video recordings.
System Zone	Select the appropriate time zone for your location.
Date Format	Choose the display format for year, month and day.
Date Separator	Select the separator between date components.
Time Format	Select the time format between 24-hour and 12-hour.
DST	Enable/disable the DST (Daylight Saving Time) as needed.
DST Type	Choose between date-based or week-based DST rules.
Start/End Time	Set the start/end time of the DST.

5.10.3 Account

Includes account modification, security question configurations for password recovery and lockout policy settings to prevent brute-force attacks.

5.10.3.1 User Account

This section explains how to add, edit, and delete user accounts on the NVR system. Right-click on the live interface and navigate to **Main Menu > System > Account > User Account**.

Figure 5-68 User Account

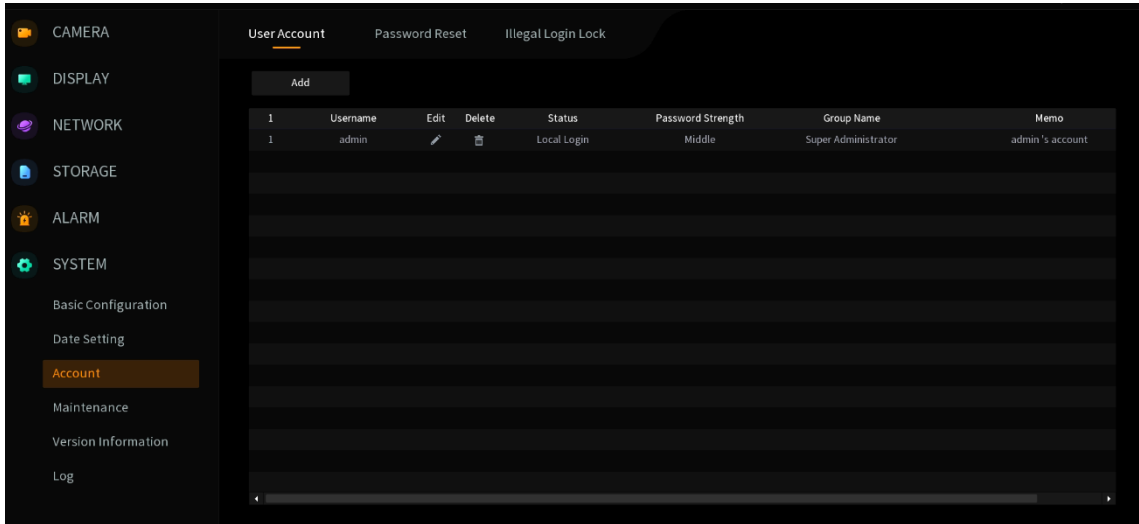

Add Account



This function is exclusive to admin account.

Step 1 Right-click on the live interface and navigate to **Main Menu > System > Account > User Account**.

Step 2 Click **Add** to create an account.

Figure 5-69 Add Account

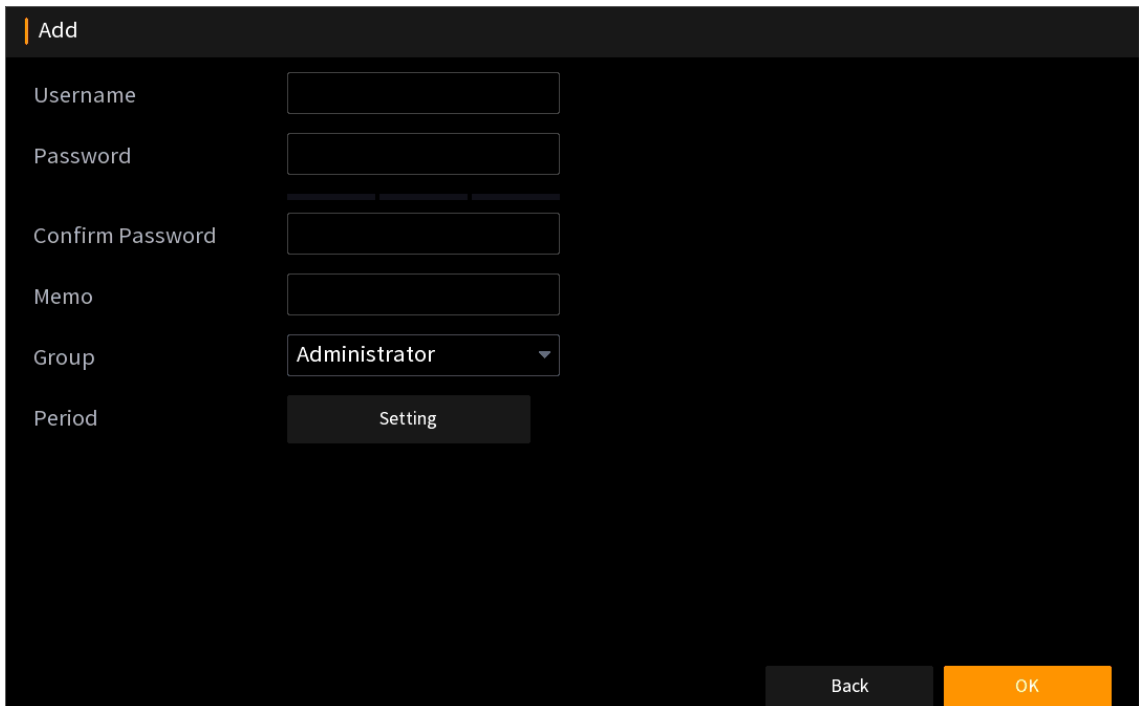

Step 3 Configure settings, then click **OK**.

Table 5-24 Add Account

Item	Description
Username	Enter the username which cannot be duplicated.
Password	Create a password for the new account.
Confirm Password	The password should be 8-32 characters long and contain at least two types from numbers, letters or symbols (except ' " ; : &). Follow the strength meter to create a high-security password.
Memo	Optional remarks for account identification.
Group	Defines permission levels: <ul style="list-style-type: none"> ● Super Administrator: Unique default admin account, not displayed in this Group option. Permanent and top level account with all operation controls and privileges like overall account management, unlock pattern, security question reset. ● Administrator: Near-full permissions with restrictions like overall account management or security question reset. ● User: Limited to live view and playback functions.
Period	Set permitted login time ranges for current account, admin excepted.

Edit Account

The account editing capabilities vary by account types. To modify an account, navigate to **Main Menu >**

System > Account > User Account, then click  of a specific account.

- Super Administrator:
 - ◇ Edit all accounts' information including its own.
 - ◇ Click  to delete other undesired accounts.
 - ◇ Modify the unlock pattern used for access verification for admin account only.
 - ◇ Modify the prompt questions serving as password reminders, exclusive to admin account.
- Other accounts: Only their own account appears in the list and they can only edit their own account information.

5.10.3.2 Reset Security Questions

Reset security questions which will be used to regain the admin password if forgotten. For the complete password recovery procedure, refer to "4.6 Admin Password Recovery."



Security questions and their reset are available only for **admin** account.

Step 1 Right-click on the live interface and navigate to **Main Menu > System > Account > Password Reset**.

Figure 5-70 Reset Security Questions

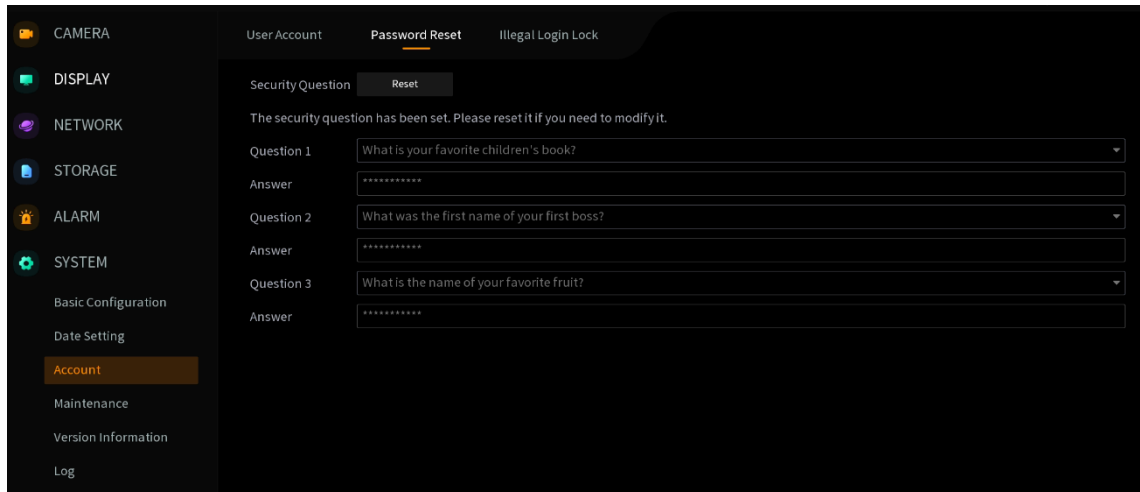

Step 2 Click **Reset**, enter new answers, then click **Apply** to save settings.

5.10.3.3 Account Lockout Policy

Define the maximum number of failed login attempts allowed before temporary account lockout, and specify the lockout duration.

Step 1 Right-click on the live interface and navigate to **Main Menu > System > Account > Illegal Login Lock**.

Step 2 Configure the settings, then click **Apply**.

- **Attempt(s):** The maximum number of incorrect login attempts allowed before the account is locked.
- **Lock Time:** How long the account remains locked after exceeding the allowed login attempts before it returns to normal.

Figure 5-71 Account Lockout Policy

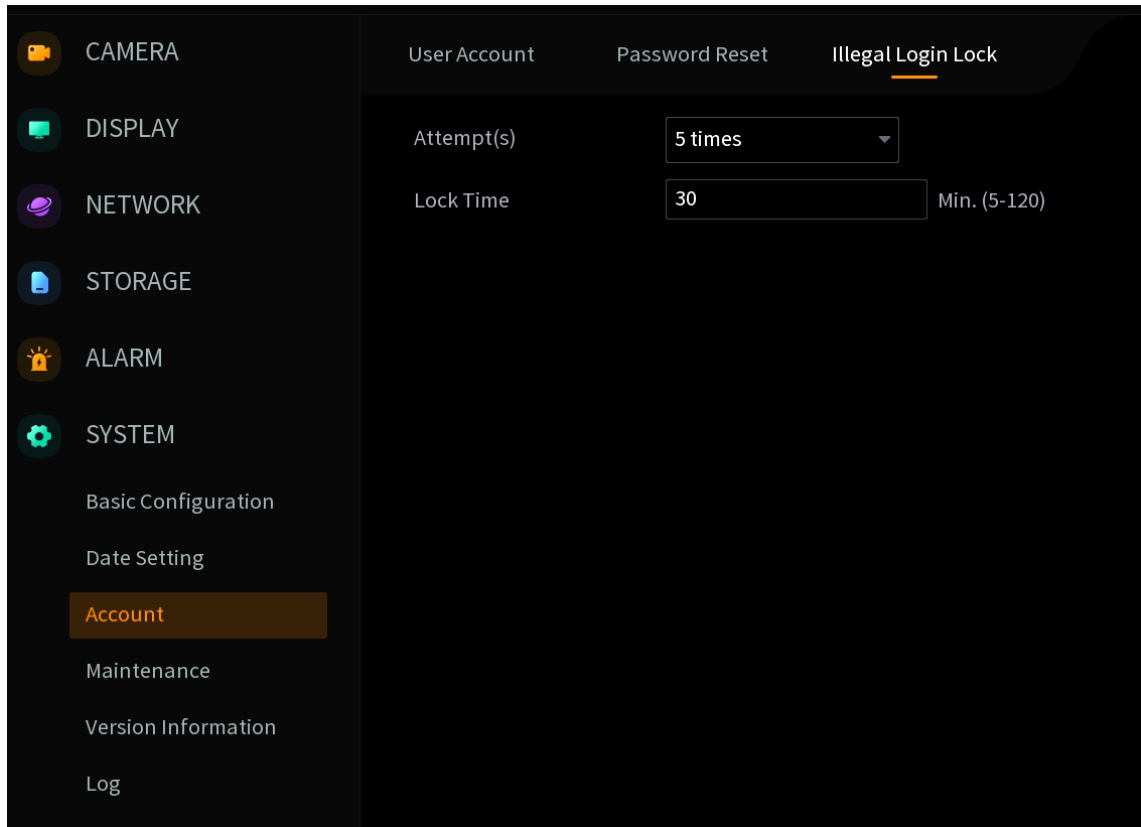

5.10.4 Maintenance

Keeps the NVR running smoothly or resolve critical issues with scheduled restarts, system upgrade and restore defaults.

5.10.4.1 Auto Reboot

Configure the NVR to automatically reboot during idle periods to maintain optimal performance and system efficiency.

Step 1 Right-click on the live interface and navigate to **Main Menu > System > Maintenance > Auto Maintenance**.

Figure 5-72 Auto Maintenance

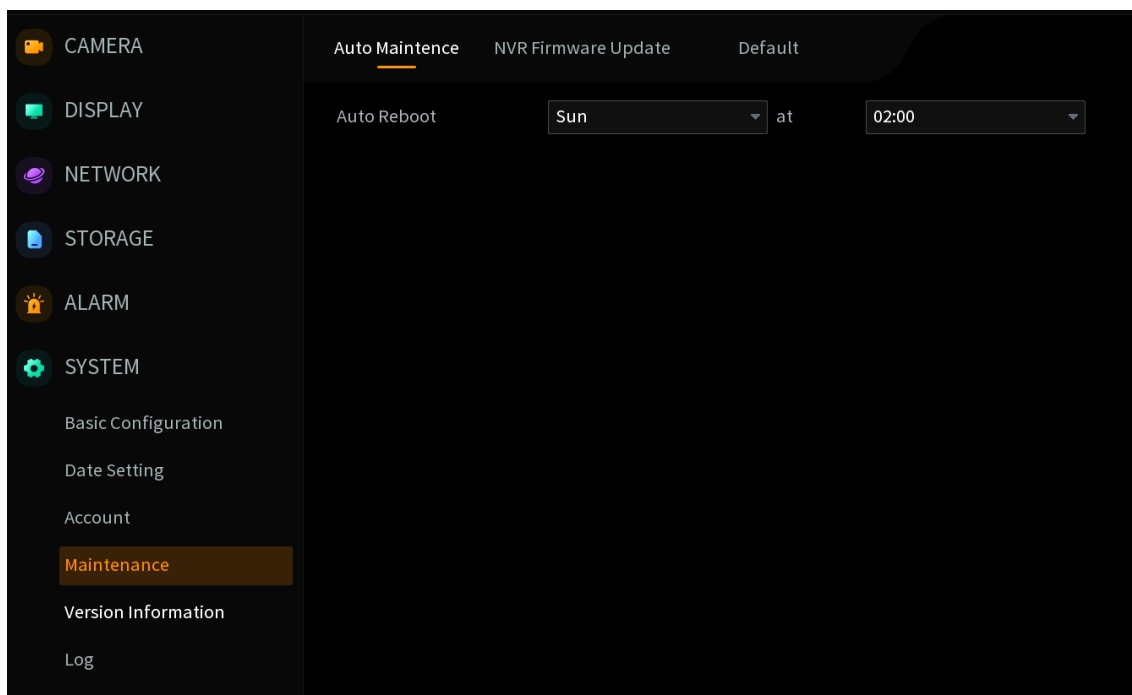

- Step 2 Select your preferred reboot frequency and set the exact time (recommended during low-activity periods).
- Step 3 Click **Apply** to save settings.

5.10.4.2 System Upgrade

Maintain your NVR's performance and security by upgrading its firmware. Two methods are available: local upgrade (via USB) or online upgrade (via Internet connection).



Do not power off the NVR during upgrade.

File Upgrade

Connect the USB storage device with upgrade files to the NVR, you can upgrade the system locally.

- Step 1 Insert a USB storage, then select **System Upgrade**.
- Step 2 Select upgrade files, then click **OK**. The system starts the upgrading.

Online Upgrade

Connect the NVR to the Internet and you can upgrade the system online.



Ensure the NVR has correctly connected to the active Internet.

- Step 1 Right-click anywhere on the live view and navigate to **Main Menu > System > Maintenance > NVR Firmware Upgrade**.
 - When **Auto Detect** is enabled, the system automatically checks for updates regularly.
 - Alternatively, you can click **Manual Check** to search for updates immediately.

Step 2 When there is a new version available, click **Upgrade Now** to start the process.

Figure 5-73 System Upgrade

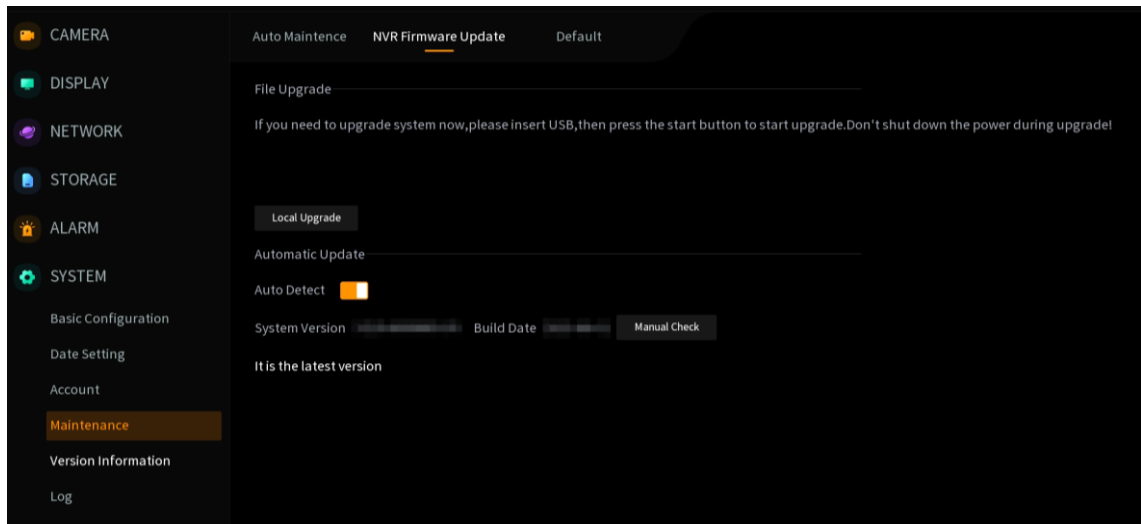

5.10.4.3 Restore Defaults

Resolve system performance issues (slow operation) or configuration errors by resetting the NVR to factory default settings.

Step 1 Right-click anywhere on the live view and navigate to **Main Menu > System > Maintenance > Default**.

Figure 5-74 Restore Defaults

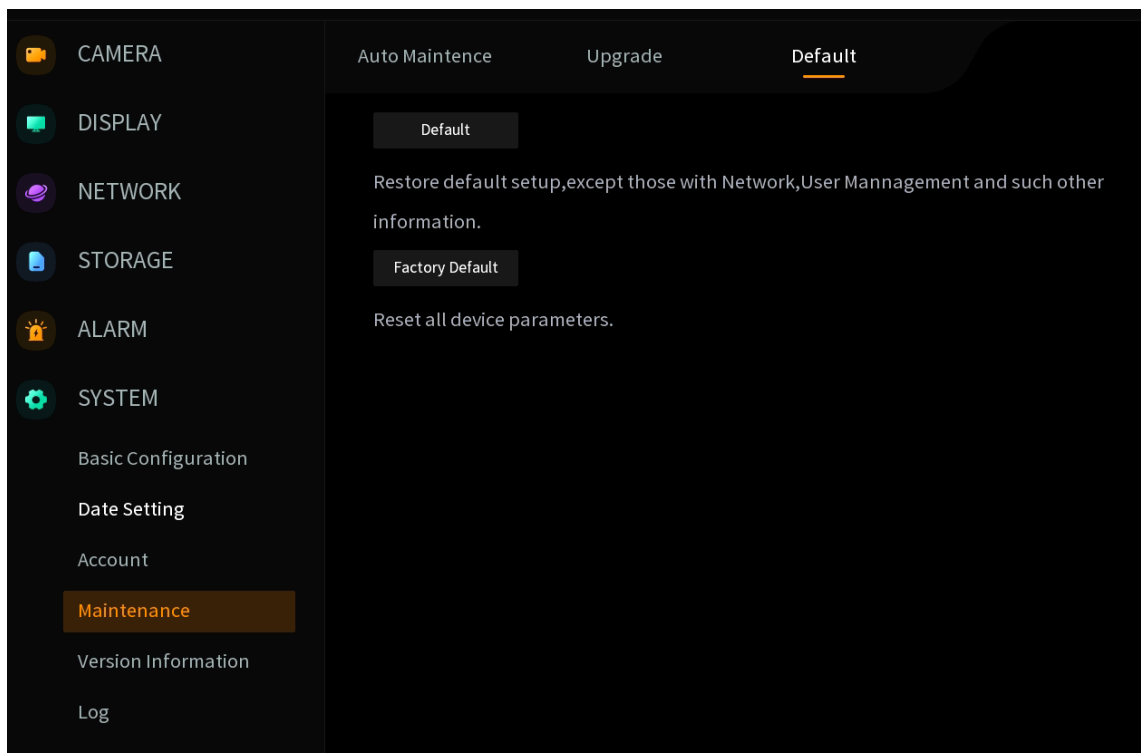

Step 2 Choose the appropriate factory reset option and confirm the action when prompted.



Factory Default is available only for admin account. It is more powerful than **Default** since all data will be removed, excluding data stored in the HDD, which can only be cleared by formatting.

5.10.5 Version Information

To view the NVR's system details (including model, supported channels, firmware version, serial number, etc.), right-click on the live view and go to **Main Menu > System > Version Information**.

Figure 5-75 Version Information

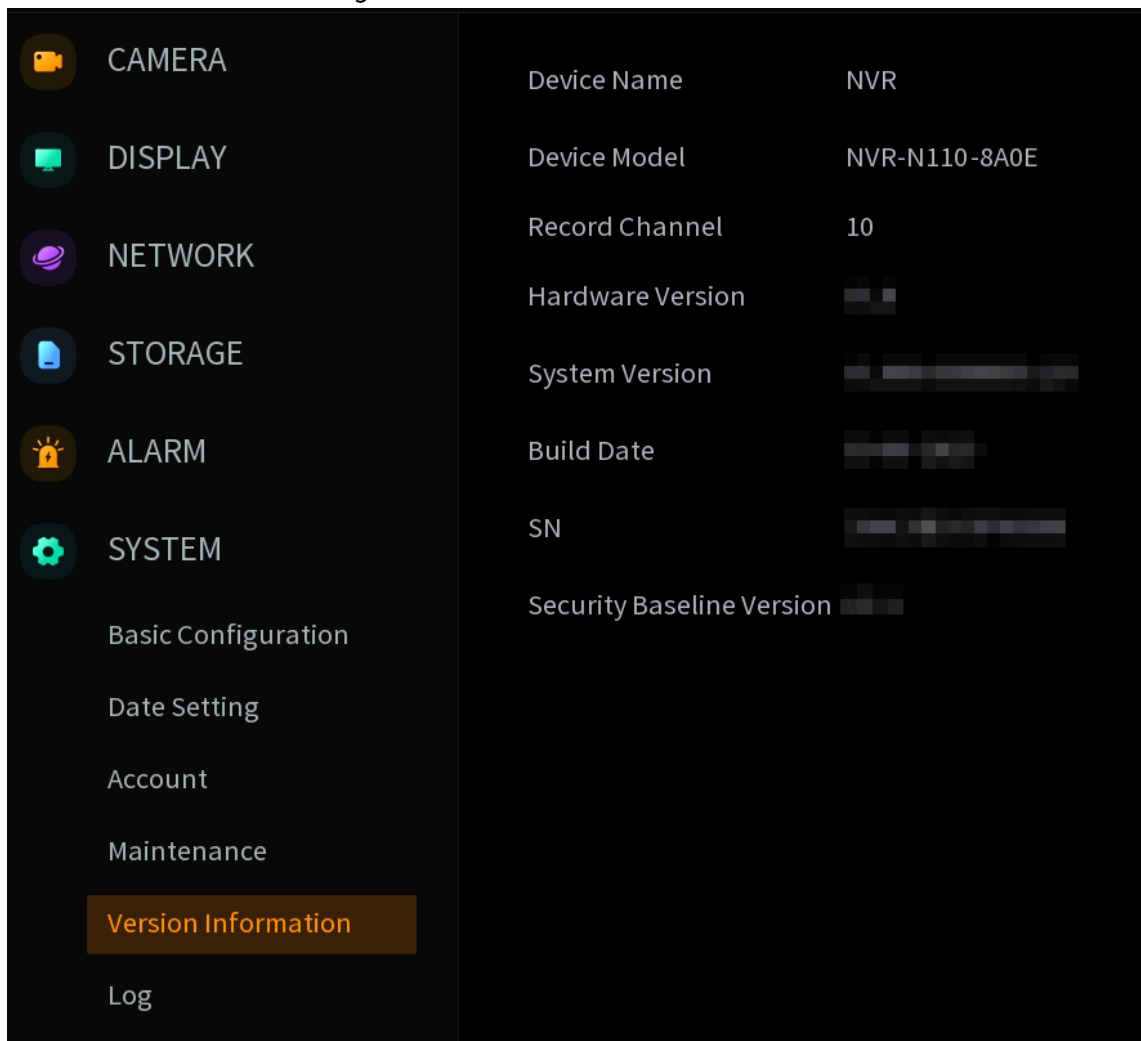

5.10.6 Log

View system logs or export logs for troubleshooting.

5.10.6.1 Log Information

View and manage alarm logs, including event details, video playback, and log exports.



Previous logs will be overwritten once the entry number reaches the limit. Please save important logs regularly.

Step 1 Right-click on the live interface and navigate to **Main Menu > System > Log > Log**.

Figure 5-76 Log

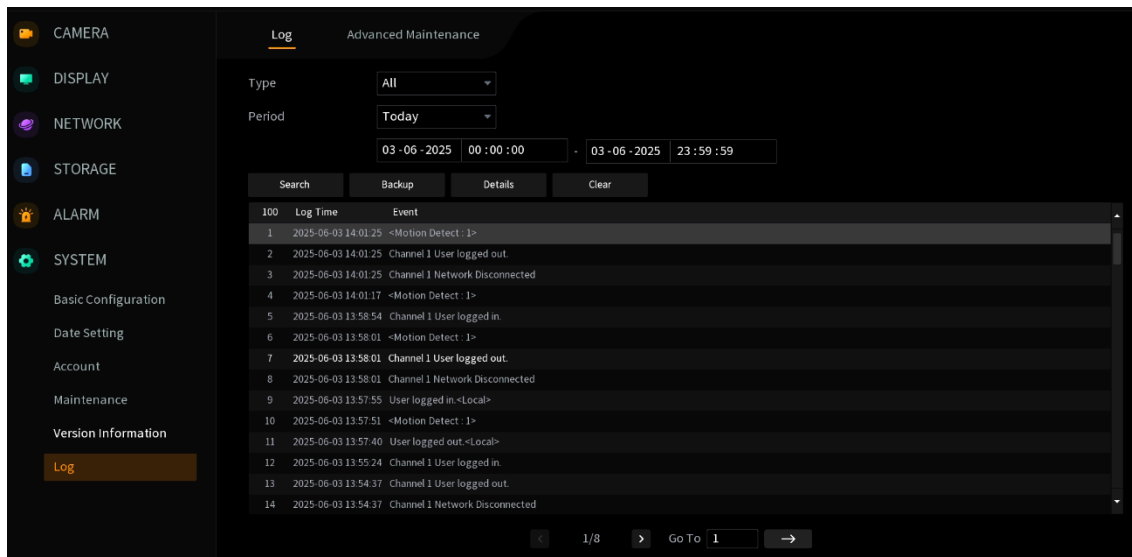

Step 2 Select the log type.

Step 3 Specify the time range, set the start/end time, then click **Search**. Matching log information will be listed where you can see the happening time, log types and more.

- Click **Backup** to export the specified logs to a USB storage device.
- Double click a log or click **Details** of the selected log to view the its detailed information (e.g., type, channel, time or videos if available).
- Click **Clear** to delete all existed logs.

5.10.6.2 Advanced Maintenance

If the NVR encounters abnormal behavior, export the system logs for technical support to diagnose the issue.

Figure 5-77 Advanced Maintenance

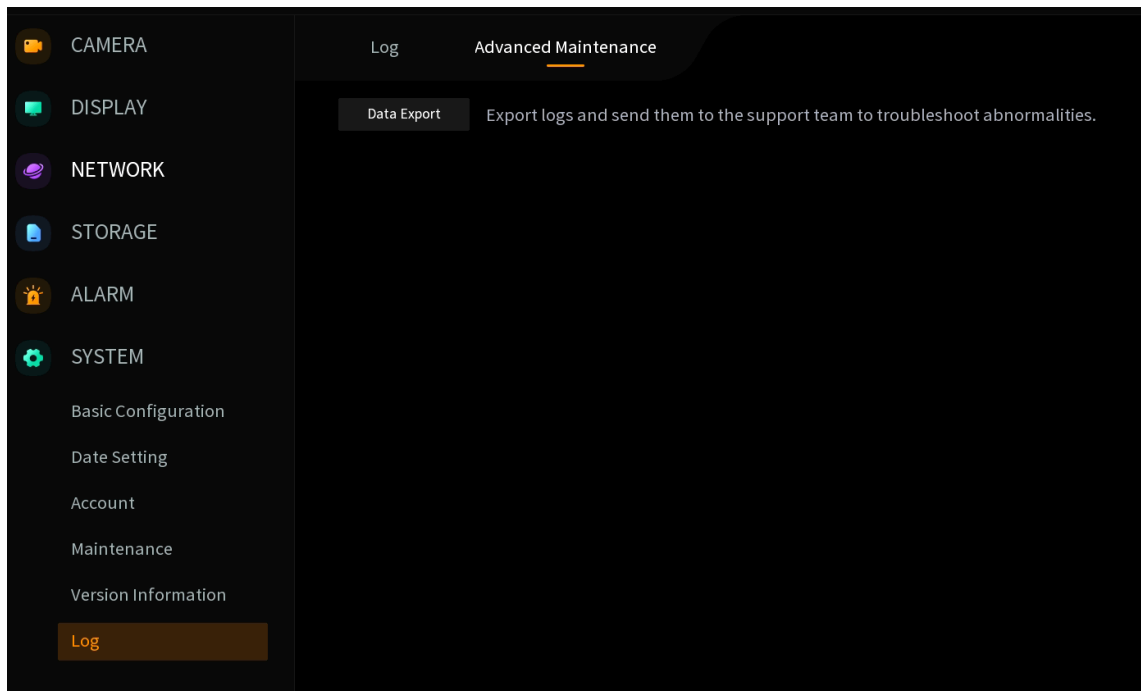

Step 1 Right-click on the live interface and navigate to **Main Menu > System > Log > Advanced Maintenance**.

Step 2 Click **Data Export**.

Step 3 Select the save path on the USB storage device, then click **OK** to export logs.

6 FAQ

Questions	Solutions
The NVR won't start properly	<ul style="list-style-type: none"> ● Please use the provided 12 VDC 2 A power adapter. ● Check the power indicator light (PWR) on the front panel. <ul style="list-style-type: none"> ◇ If the light is off, ensure the power cable is securely connected to the NVR and the outlet is functioning. ◇ If the indicator lights up green, verify the display's power and video cables are firmly seated at both ends. <p>If issues persist, please contact our technical support.</p>
Failed to add the camera to the NVR	<p>Directly connect the camera to NVR's Ethernet port, then reset the camera. After the camera reboots, right-click on the live view, and go to Main Menu > Camera > Add Devices > Search Devices. Click Search Devices button. If the camera can be detected, check if both the camera and NVR were on the same network segment range before.</p>
How to add third-party cameras to NVR	<p>Wired connections for third-party cameras are recommended. Ensure the cameras are on the same network segment as the NVR and either support the ONVIF protocol or have their ONVIF-related settings correctly configured (like username and password). Try either method below.</p> <ul style="list-style-type: none"> ● Add by manual search: Right-click on the live view. Go to Main Menu > Camera > Add Devices > Search Devices. Click Search Devices button. Double-click the detected camera to add it. Once added, enter camera's own username and password by clicking  and save changes. ● Add by information entry: Right-click on the live view. Go to Main Menu > Camera > Add Devices > Search Devices. Click Manual Add button. Select Onvif as the protocol, enter camera's IP address and password, then click OK.
What to do if the live streaming lags after the camera has been connected to the NVR	<p>Directly connect the camera to NVR's Ethernet port. If the stream stabilizes, inspect the Ethernet cable and router/switch to ensure they are capable of high-speed transmission.</p>

Questions	Solutions
No recordings available for playback	<p>Check the hard drive indicator light (HDD) on the front panel. If it glows red, follow the steps below to verify:</p> <ol style="list-style-type: none"> 1. Inspect cable connections: Check if HDD's power and data cables are properly connected and secure. 2. Verify HDD status: Look for "No HDD" or "HDD error" alerts in the upper-left corner of the live interface, or right-click on the live view and navigate to Main Menu > Storage > HDD Manager to check the drive's status. Replace it if there are any abnormalities.
How to add the NVR to Imou Life App	See "5.7.3 Cloud Services."

Appendix 1 Cybersecurity Recommendations

Cybersecurity is more than just a buzzword: it's something that pertains to every device that is connected to the internet. IP video surveillance is not immune to cyber risks, but taking basic steps toward protecting and strengthening networks and networked appliances will make them less susceptible to attacks. Below are some tips and recommendations from Imou on how to create a more secured security system.

Mandatory actions to be taken for basic device network security:

1. Use Strong Passwords

Please refer to the following suggestions to set passwords.

- The length should not be less than 8 characters.
- Include at least two types of characters; character types include upper and lower case letters, numbers and symbols.
- Do not contain the account name or the account name in reverse order.
- Do not use continuous characters, such as 123, abc, etc.
- Do not use overlapped characters, such as 111, aaa, etc.

2. Update Firmware and Client Software in Time

- According to the standard procedure in Tech-industry, we recommend to keep your device (such as NVR, DVR, IP camera, etc.) firmware up-to-date to ensure the system is equipped with the latest security patches and fixes. When the device is connected to the public network, it is recommended to enable the "auto-check for updates" function to obtain timely information of firmware updates released by the manufacturer.
- We suggest that you download and use the latest version of client software.

"Nice to have" recommendations to improve your device network security:

1. Physical Protection

We suggest that you perform physical protection to device, especially storage devices. For example, place the device in a special computer room and cabinet, and implement well-done access control permission and key management to prevent unauthorized personnel from carrying out physical contacts such as damaging hardware, unauthorized connection of removable device (such as USB flash disk, serial port), etc.

2. Change Passwords Regularly

We suggest that you change passwords regularly to reduce the risk of being guessed or cracked.

3. Set and Update Passwords Reset Information Timely

The device supports password reset function. Please set up related information for password reset in time, such as password protection questions. If the information changes, please modify it in time. When setting password protection questions, it is suggested not to use those that can be easily guessed.

4. Enable Account Lock

The account lock feature is enabled by default, and we recommend you to keep it on to guarantee the account security. If an attacker attempts to log in with the wrong password several times, the corresponding account and the source IP address will be locked.

5. Change Default HTTP and Other Service Ports

We suggest you to change default HTTP and other service ports into any set of numbers between 1024–65535, reducing the risk of outsiders being able to guess which ports you are using.

6. Enable HTTPS

We suggest you to enable HTTPS, so that you visit Web service through a secure communication channel.

7. MAC Address Binding

We recommend you to bind the IP and MAC address of the gateway to the device, thus reducing the risk of ARP spoofing.

8. Assign Accounts and Privileges Reasonably

According to business and management requirements, reasonably add users and assign a minimum set of permissions to them.

9. Disable Unnecessary Services and Choose Secure Modes

If not needed, it is recommended to turn off some services such as SNMP, SMTP, UPnP, etc., to reduce risks.

If necessary, it is highly recommended that you use safe modes, including but not limited to the following services:

- SNMP: Choose SNMP v3, and set up strong encryption passwords and authentication passwords.
- SMTP: Choose TLS to access mailbox server.
- FTP: Choose SFTP, and set up strong passwords.
- AP hotspot: Choose WPA2-PSK encryption mode, and set up strong passwords.

10. Audio and Video Encrypted Transmission

If your audio and video data contents are very important or sensitive, we recommend that you use encrypted transmission function, to reduce the risk of audio and video data being stolen during transmission.

Reminder: encrypted transmission will cause some loss in transmission efficiency.

11. Secure Auditing

- Check online users: we suggest that you check online users regularly to see if the device is logged in without authorization.
- Check device log: By viewing the logs, you can know the IP addresses that were used to log in to your devices and their key operations.

12. Network Log

Due to the limited storage capacity of the device, the stored log is limited. If you need to save the log for a long time, it is recommended that you enable the network log function to ensure that the critical logs are synchronized to the network log server for tracing.

13. Construct a Safe Network Environment

In order to better ensure the safety of device and reduce potential cyber risks, we recommend:

- Disable the port mapping function of the router to avoid direct access to the intranet devices from external network.
- The network should be partitioned and isolated according to the actual network needs. If there are no communication requirements between two sub networks, it is suggested to use VLAN, network GAP and other technologies to partition the network, so as to achieve the network isolation effect.
- Establish the 802.1x access authentication system to reduce the risk of unauthorized access to private networks.
- Enable IP/MAC address filtering function to limit the range of hosts allowed to access the device.